

CIC-14 REPORT COLLECTION  
**REPRODUCTION**  
**COPY**

LA-2203

0.3

**LOS ALAMOS SCIENTIFIC LABORATORY**  
**OF THE UNIVERSITY OF CALIFORNIA ○ LOS ALAMOS NEW MEXICO**

---

**CRITICAL MASSES OF URANALLOY IN THIN REFLECTORS**

LOS ALAMOS NATL. LAB. LIBS.



3 9338 00359 4602

## LEGAL NOTICE

This report was prepared as an account of Government sponsored work. Neither the United States, nor the Commission, nor any person acting on behalf of the Commission:

A. Makes any warranty or representation, express or implied, with respect to the accuracy, completeness, or usefulness of the information contained in this report, or that the use of any information, apparatus, method, or process disclosed in this report may not infringe privately owned rights; or

B. Assumes any liabilities with respect to the use of, or for damages resulting from the use of any information, apparatus, method, or process disclosed in this report.

As used in the above, "person acting on behalf of the Commission" includes any employee or contractor of the Commission to the extent that such employee or contractor prepares, handles or distributes, or provides access to, any information pursuant to his employment or contract with the Commission.

LA-2203  
CRITICALITY STUDIES  
(TID-4500, 13th ed., rev.)

**LOS ALAMOS SCIENTIFIC LABORATORY**  
**OF THE UNIVERSITY OF CALIFORNIA LOS ALAMOS NEW MEXICO**

REPORT WRITTEN: January 1958

REPORT DISTRIBUTED: July 16, 1958

**CRITICAL MASSES OF ORALLOY IN THIN REFLECTORS**

Work done by:

Members of Group N-2

Particularly:

K. W. Gallup (now with  
U. S. Air Force)

G. E. Hansen

H. C. Paxton

R. H. White

Report written by:

G. E. Hansen

H. C. Paxton

D. P. Wood

This report expresses the opinions of the author or authors and does not necessarily reflect the opinions or views of the Los Alamos Scientific Laboratory.

Contract W-7405-ENG. 36 with the U. S. Atomic Energy Commission



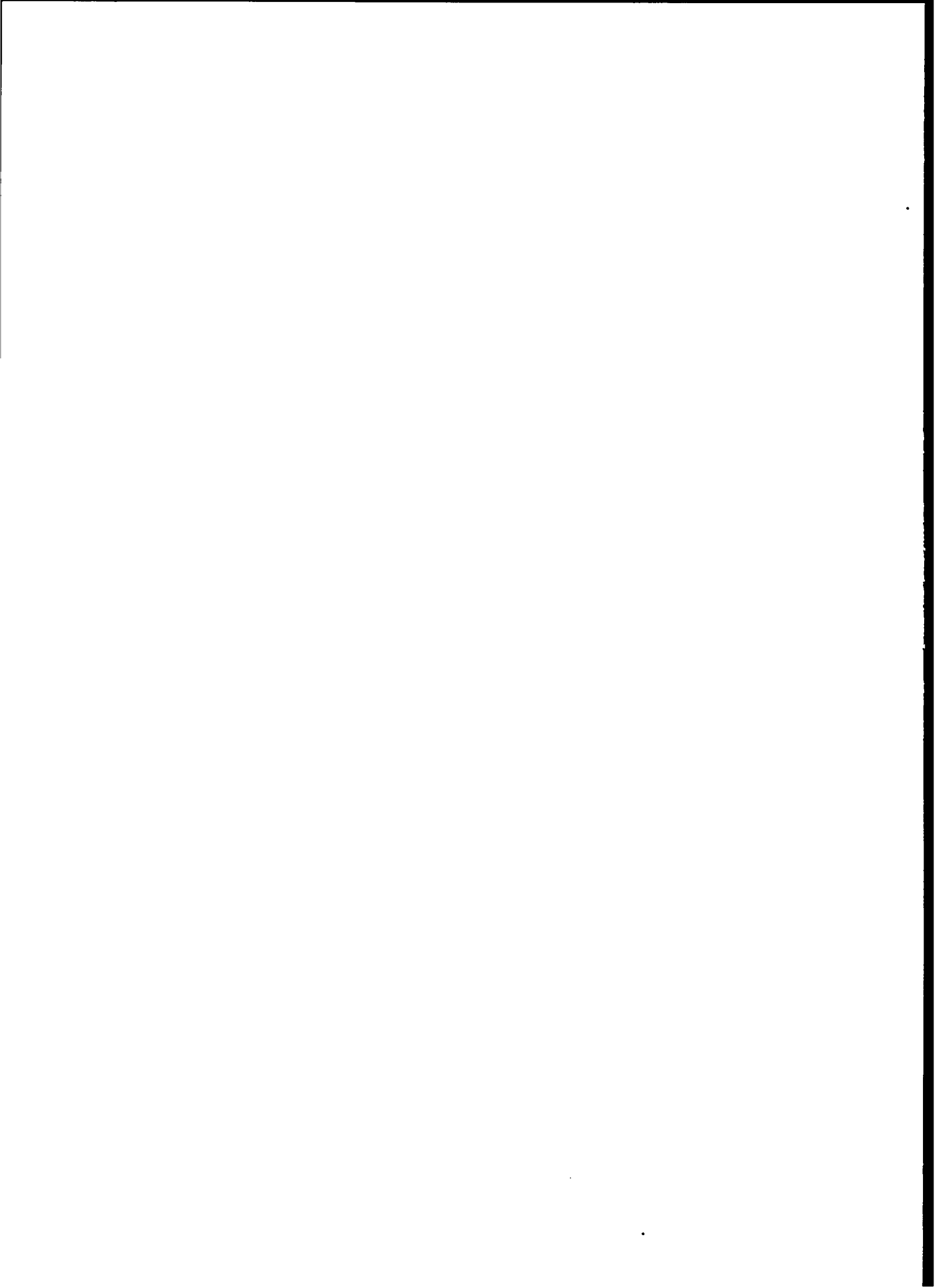

## ABSTRACT

Critical masses have been measured for 5-1/4 in. diameter Oy cylinders in 1/2 and 1 in. thick reflectors of Be, graphite, Mg, Al, Ti, mild steel, Cu, W alloy, Tu, Ni, Co, Mo,  $\text{Al}_2\text{O}_3$ ,  $\text{Mo}_2\text{C}$ , and polythene. These results have been converted to the equivalent spherical critical masses of Oy and compared to yield consistent transport cross sections for the reflector materials.

In addition, critical masses of Oy spheres in ~2 and ~4 in. thick spherical reflectors of W alloy, Fe, Ni, Ni-silver, Cu, Zn, Th, Be, BeO, C, and Tu have been determined.



## CONTENTS

|   | <u>Page</u> |
|---|-------------|
| Abstract . . . . .  | 3           |
| 1. Critical Masses of Oy Cylinders in Thin Reflectors . . . . .                       | 7           |
| 2. Critical Mass Measurements of Oy Spheres in 2 and 4 In. Thick Reflectors . . . . . | 23          |

## ILLUSTRATIONS

|  |    |
|--|----|
| Fig. 1 Photograph of the Oy Cylinder-Reflector Test Setup on Comet . . . . .   | 9  |
| Fig. 2 Schematic of the Oy Cylinder-Reflector Test Setup on Comet . . . . .  | 10 |
| Fig. 3 Photograph of a Typical 1 In. Thick Reflector Geometry . . . . .  | 12 |
| Fig. 4 Curve of Effective Extrapolation Length $\lambda$ vs. $(h/d)/(1 + h/d)$ for Several Reflectors<br>$\lambda_{OS}(\text{Sphere}) \equiv 2.15 \text{ Cm.}$ . . . . . | 17 |
| Fig. 5 Curve of $\lambda$ vs. $(h/d)/(1 + h/d)$ with<br>$\lambda_{OS}(\text{Sphere}) \equiv 1.05 \text{ Cm.}$ . . . . .  | 18 |
| Fig. 6 Schematic of Oy Sphere-Reflector Test Setup on Comet . . . . .  | 24 |
| Fig. 7 Photograph of Typical 2 and 4 In. Thick Reflectors . . . . .  | 26 |

CONTENTS (Continued)

|  | <u>Page</u> |
|--|-------------|
| Fig. 8 Plot of $m_c(Oy)$ vs. Reflector Thickness for Fe, Ni, and W Alloy . . . . . | 33          |
| Fig. 9 Plot of $m_c(Oy)$ vs. Reflector Thickness for Cu and Graphite . . . . .     | 34          |
| Fig. 10 Plot of $m_c(Oy)$ vs. Reflector Thickness for Be and Tu . . . . .          | 35          |

TABLES

|   |    |
|---|----|
| Table I Or alloy Cylinders Used in Measurements . . .   | 8  |
| Table II Critical Masses of Oy in 1/2 and 1 In. Thick Reflectors of Various Materials . . .   | 15 |
| Table III Corresponding Relative Transport Cross Sections of the Reflector Materials . . .    | 21 |
| Table IV Critical Masses of Spherical Oy in ~2 and ~4 In. Thick Spherical Reflectors. . . . . | 28 |



## 1. CRITICAL MASSES OF Oy CYLINDERS IN THIN REFLECTORS

A method of determining transport cross sections for thin reflectors at the Pajarito remote-control laboratory at Los Alamos is described in this report. First, the critical masses were determined for 5-1/4 in. diameter Oy( $\sim$ 93.5)\* cylinders in 1/2 and 1 in. thick reflectors of Be, graphite, Mg, Al, Ti, mild steel, Cu, W alloy, Tu, Ni, Co, Mo, Al<sub>2</sub>O<sub>3</sub>, Mo<sub>2</sub>C, and polythene. From these data, corresponding spherical critical masses reflector savings were calculated. Finally from these reflector savings, the relative transport cross sections of the reflector materials were estimated and compared with those obtained from danger coefficient measurements with the Topsy Oy-tuballoy (Tu) reflected and Godiva Oy unreflected critical assemblies.

### 1.1 Facilities

#### 1.1.1 Assembly Machine

The Comet universal machine was utilized. This machine consists of a hydraulic lift (ram) with a stationary platform directly above it. In this experiment, the platform was

\*Oralloy (symbol "Oy") designates uranium enriched in U<sup>235</sup>. Oy(93.5) indicates uranium that is 93.5 w/o U<sup>235</sup>.

a 15 mil stainless steel diaphragm. Figure 1 is a photograph of the test setup on the Comet machine.

### 1.1.2 Fissile Material

A typical assembly is illustrated in Fig. 2. The diameter of the Oy was chosen to give a regular cylinder for ~35 kg of Oy, so that shape-factor corrections would be small over the estimated 30 to 40 kg range of Oy for the various final configurations. The 40 kg of Oy available for this series of measurements was in the form of 5-1/4 in. diameter cylinders as listed in Table I. These pieces were duplicated in Tu.

TABLE I  
ORALLOY CYLINDERS USED IN MEASUREMENTS

| <u>Thickness,<br/>in.</u>  | <u>Number<br/>Required</u> | <u>Approximate<br/>Weight,<br/>kg</u> |
|----------------------------|----------------------------|---------------------------------------|
| 1.200 ± 0.002              | 3                          | 8 (each)                              |
| 0.600 ± 0.002              | 1                          | 4                                     |
| 0.300 ± 0.002              | 1                          | 2                                     |
| 0.150 ± 0.002              | 1                          | 1                                     |
| 0.075 ± 0.002              | 1                          | 0.5                                   |
| 1.200 ± 0.002 <sup>a</sup> | 1                          | 7.96                                  |
| 0.075 ± 0.002              | 2                          | 0.25 (each)                           |

a. Equipped with central cavity for neutron source.

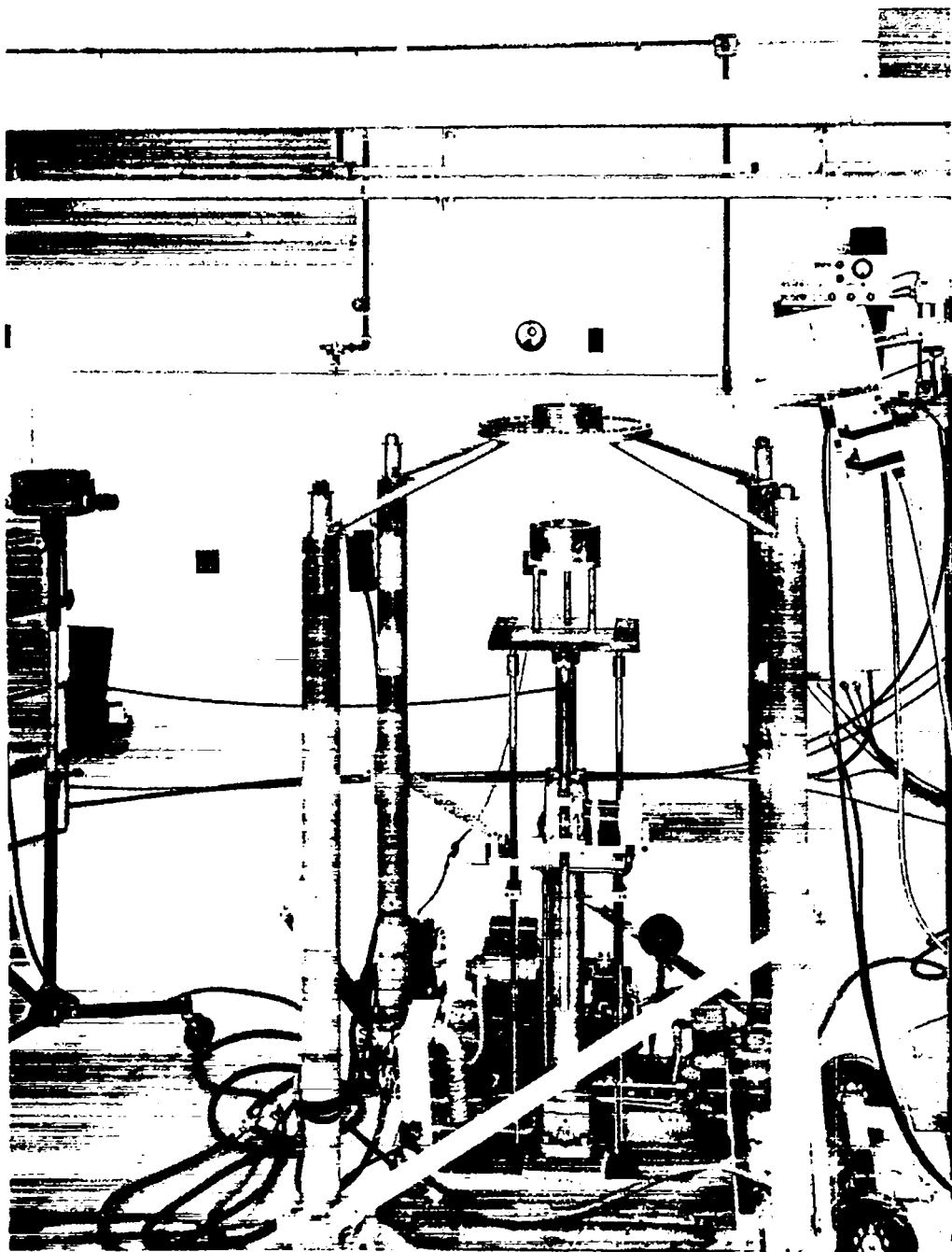

Fig. 1 Photograph of the O<sub>y</sub> cylinder-reflector test setup on Comet.

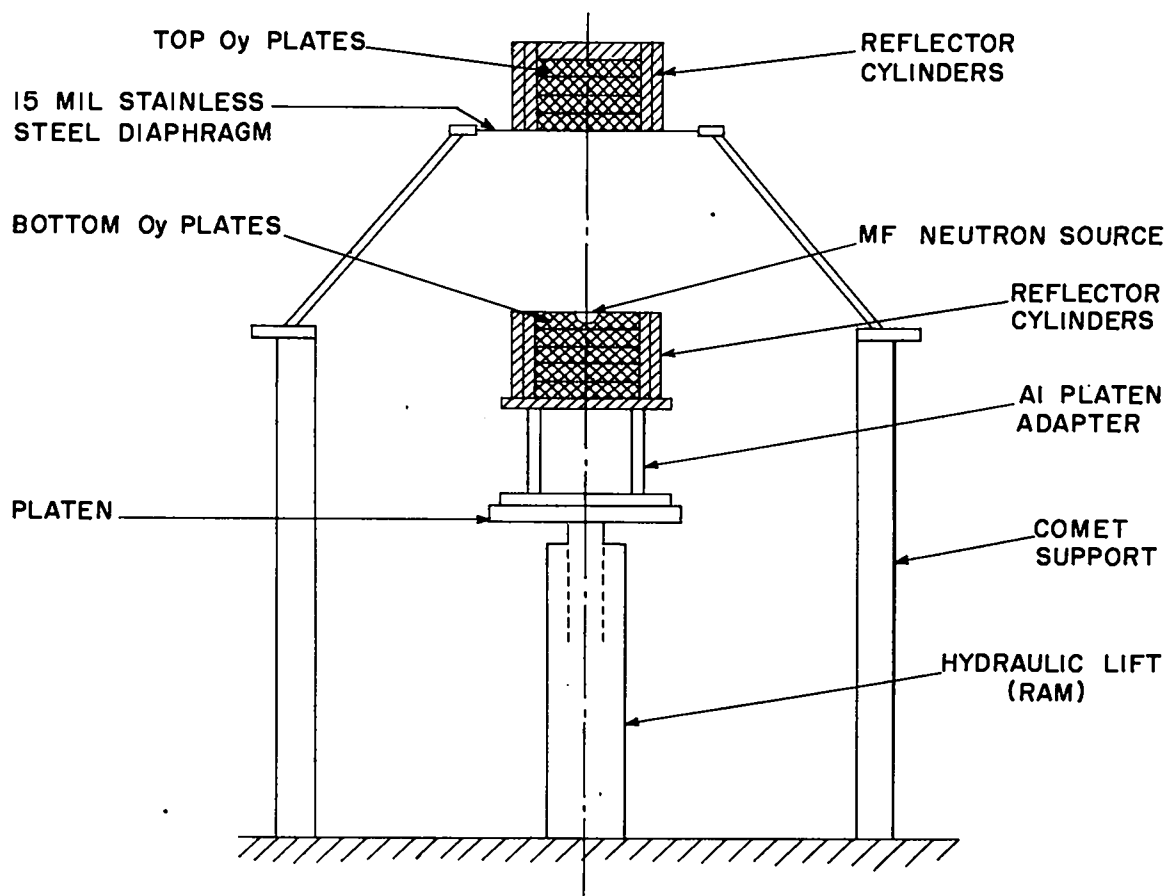

Fig. 2 Schematic of the Oy cylinder-reflector test setup on Comet.

### 1.1.3 Reflector Material

Concentric 1/2 in. thick cylindrical reflectors of the interesting materials, supplemented by plates, permitted assemblies of 1/2 and 1 in. thick reflectors. Figure 3 is an exploded view of a typical 1 in. thick reflector geometry. In addition, blocks of Be, Fe, and Tu were used for thickened (i.e., >1 in.) reflector bases.

### 1.1.4 Neutron Source and Counters

A mock-fission (MF-20) neutron source was centered in the Oy assembly for all tests. The source was located in a cavity in the top Oy plate on the ram. Four boron-lined neutron counters, in long-counter geometries, were located on lifts and placed close to the assembly for monitoring the neutron leakage.

## 1.2 Neutron Multiplication

Neutron multiplication data were obtained by first taking unmultiplied counting rates and then multiplied counting rates for each given geometry. The unmultiplied count was obtained by recording the counting rates of the four counters with source MF-20 positioned in the assembly loaded with Tu mockups of the Oy components. Next, the Oy components replaced the Tu and again the counting rates were recorded. The ratio of multiplied counting rate to

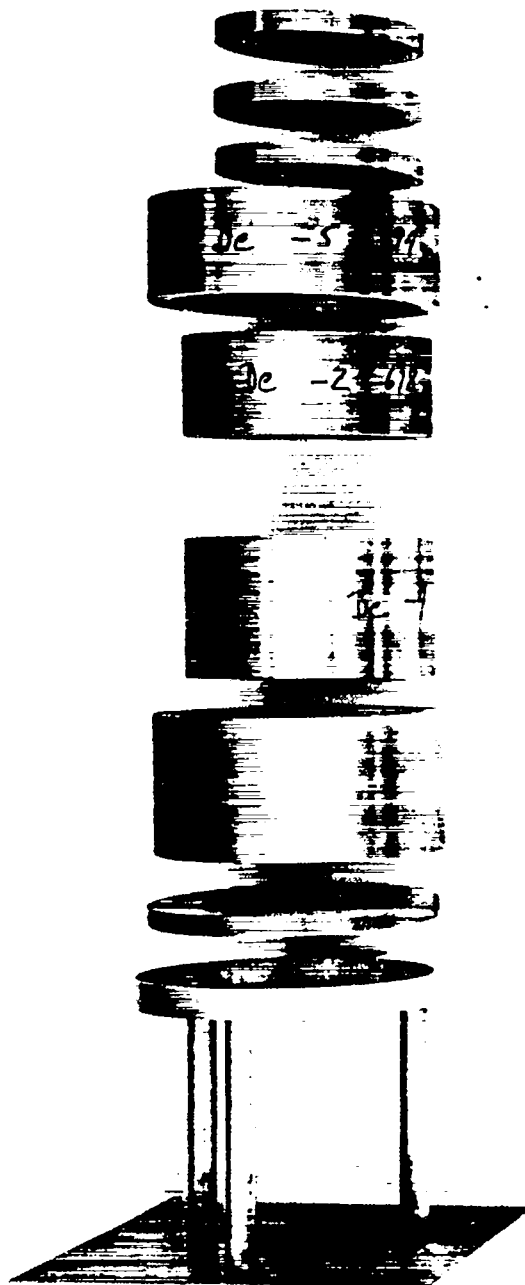

Fig. 3 Photograph of a typical 1 in. thick reflector geometry.

unmultiplied counting rate determined the multiplication.

### 1.3 Safety

Throughout the tests on the Comet, three safety monitors placed at varying distances from the assembly were used. Any one of these monitors would separate the active material by dropping the ram if the neutron leakage exceeded a predetermined level. Only one scram (i.e., gravity) was available. Safety rules require that planned multiplications do not exceed 100 under this type of operating condition.

### 1.4 Procedure

The experimental setup is shown in Fig. 2. Approximately half of the Oy cylinder and reflector was stacked on a light platform on the hydraulic lift. The neutron source was placed in the cavity of the top Oy plate. Part of the top Oy cylinder and reflector was stacked on the diaphragm. Oralloid discs were added to the top Oy cylinder to increase the reactivity in safe steps. A progressive plot of  $1/M$  vs. Oy mass permitted extrapolation to a critical mass for the assembly under investigation.

Correction for the presence of the stainless steel diaphragm which supported the upper portion of the assembly was based on multiplication changes when the stainless steel thickness was doubled. Also, correction for incidental

reflection was determined through variation of platen thickness.

## 1.5 Critical Mass Data and Analysis

### 1.5.1 Cylinder-to-Sphere Conversions

The cylinder critical mass data are listed in Table II, together with estimated equivalent spherical critical masses and corresponding reflector savings for the different reflector materials. The shape conversion is based on critical mass data for O<sub>y</sub> cylinders and spheres given in LA-1958\* and reproduced here in Figs. 4 and 5 in terms of effective extrapolation lengths  $\lambda$ . (These figures give alternative presentations of the same data.) In these figures, the effective extrapolation length for any critical cylinder of core height  $h$  and core diameter  $d$  is defined by

$$\left(\frac{4.81}{d + 2\lambda}\right)^2 + \left(\frac{\pi}{h + 2\lambda}\right)^2 = \left(\frac{\pi}{r_o + \lambda_{os}}\right)^2 \quad (1)$$

whereas for a critical sphere of core radius  $r$ ,  $\lambda_s$  is defined by

$$\left(\frac{\pi}{r + \lambda_s}\right)^2 = \left(\frac{\pi}{r_o + \lambda_{os}}\right)^2$$

---

\*H. C. Paxton, Critical Masses of Fissionable Metals as Basic Nuclear Safety Data, Los Alamos Scientific Laboratory Report LA-1958, January 1955.



TABLE II  
CRITICAL MASSES OF Oy IN 1/2 AND 1 INCH  
THICK REFLECTORS OF VARIOUS MATERIALS

| Reflector               |                   | Ratio of<br>Cylinder<br>Height to<br>Diameter | $m_c$ (cyl.), <sup>a</sup><br>kg | $m_c$ (sphere), <sup>a</sup><br>kg | Reflector<br>Savings,<br>cm Oy (93.5) | Ref. Sav.<br>1.159 (= Ni) | Ref. S.<br>1.18 (= Fe) |
|-------------------------|-------------------|---|----------------------------------|------------------------------------|---------------------------------------|---------------------------|------------------------|
| Material<br>and Density | Thickness,<br>in. |   |                                  |                                    |                                       |                           |                        |
| Mg (FS-1)               | 1                 | 1.48 <sub>4</sub>                             | 50.7                             | 42.7                               | 0.55 <sub>4</sub>                     |                           |                        |
| 1.77 gm/cm <sup>3</sup> | 1/2               | 1.69 <sub>1</sub>                             | 57.6                             | 45.5                               | 0.37 <sub>8</sub>                     |                           |                        |
| Ti (96.5 w/o)           | 1                 | 1.40 <sub>1</sub>                             | 47.8                             | 41.3                               | 0.64 <sub>6</sub>                     |                           |                        |
| 4.50 gm/cm <sup>3</sup> | 1/2               | 1.63 <sub>3</sub>                             | 55.7                             | 44.8                               | 0.42 <sub>0</sub>                     |                           |                        |
| Al (2S)                 | 1                 | 1.37 <sub>6</sub>                             | 46.9                             | 40.8                               | 0.67 <sub>6</sub>                     |                           |                        |
| 2.70 gm/cm <sup>3</sup> | 1/2               | 1.61 <sub>9</sub>                             | 55.2                             | 44.6                               | 0.43 <sub>3</sub>                     |                           |                        |
| Graphite (CS-312)       | 1                 | 1.17 <sub>2</sub>                             | 40.1 <sub>0</sub>                | 36.7 <sub>5</sub>                  | 0.95 <sub>2</sub>                     |                           |                        |
| 1.67 gm/cm <sup>3</sup> | 1/2               | 1.44 <sub>1</sub>                             | 49.2 <sub>8</sub>                | 42.0 <sub>3</sub>                  | 0.59 <sub>7</sub>                     |                           |                        |
| Fe (SAE 1020)           | 1                 | 1.19 <sub>3</sub>                             | 40.8 <sub>1</sub>                | 37.2 <sub>3</sub>                  | 0.91 <sub>8</sub> = Fe                | 0.79                      | 1.00                   |
| 7.78 gm/cm <sup>3</sup> | 1/2               | 1.44 <sub>0</sub>                             | 49.2 <sub>3</sub>                | 42.0 <sub>6</sub>                  | 0.59 <sub>4</sub>                     |                           |                        |
| Ni (electrolytic)       | 1                 | 1.05 <sub>3</sub>                             | 36.0 <sub>8</sub>                | 33.8 <sub>9</sub>                  | 1.15 <sub>9</sub> = Ni                | 1.00                      | 1.26                   |
| 8.79 gm/cm <sup>3</sup> | 1/2               | 1.30 <sub>8</sub>                             | 44.7 <sub>7</sub>                | 39.6 <sub>4</sub>                  | 0.75 <sub>4</sub>                     |                           |                        |
| Cu (99-99.5 w/o)        | 1                 | 1.03 <sub>7</sub>                             | 35.5 <sub>6</sub>                | 33.5 <sub>0</sub>                  | 1.18 <sub>8</sub> = Cu                | 1.02                      | 1.29                   |
| 8.87 gm/cm <sup>3</sup> | 1/2               | 1.31 <sub>0</sub>                             | 44.8 <sub>3</sub>                | 39.6 <sub>7</sub>                  | 0.75 <sub>2</sub>                     |                           |                        |
| Co (reagent)            | 1                 | 1.03 <sub>3</sub>                             | 35.4 <sub>1</sub>                | 33.3 <sub>9</sub>                  | 1.19 <sub>6</sub> = Co                | 1.03                      | 1.30                   |
| 8.72 gm/cm <sup>3</sup> | 1/2               | 1.28 <sub>9</sub>                             | 44.1 <sub>3</sub>                | 39.2 <sub>8</sub>                  | 0.77 <sub>8</sub>                     |                           |                        |

TABLE II (Continued)

| Reflector   |                   | Ratio of<br>Cylinder<br>Height to<br>Diameter | $m_c$ (cyl.), <sup>a</sup><br>kg | $m_c$ (sphere), <sup>a</sup><br>kg | Reflector<br>Savings,<br>cm Oy (93.5)   | Ref. S.<br>1.159 (=Ni) |
|---|-------------------|---|----------------------------------|------------------------------------|---|------------------------|
| Material<br>and Density   | Thickness,<br>in. |   |                                  |                                    |   |                        |
| Mo (99.8 w/o)   | 1                 | 1.02 <sub>2</sub>                             | 35.0 <sub>2</sub>                | 33.0 <sub>9</sub>                  | 1.21 <sub>9</sub> = Mo                  | 1.05 1.33              |
| 10.53 gm/cm <sup>3</sup>  | 1/2               | 1.30 <sub>0</sub>                             | 44.5 <sub>0</sub>                | 39.4 <sub>9</sub>                  | 0.76 <sub>4</sub>                       |                        |
| U (normal)  | 1                 | 0.97 <sub>5</sub>                             | 33.4 <sub>3</sub>                | 31.8 <sub>7</sub>                  | 1.31 <sub>2</sub> = U <sub>normal</sub> | 1.13 1.43              |
| 18.8 gm/cm <sup>3</sup>   | 1/2               | 1.26 <sub>3</sub>                             | 43.2 <sub>6</sub>                | 38.7 <sub>5</sub>                  | 0.81 <sub>4</sub>                       |                        |
| W (~91.3 w/o)   | 1                 | 0.98 <sub>5</sub>                             | 33.7 <sub>7</sub>                | 32.1 <sub>0</sub>                  | 1.29 <sub>4</sub> = W                   | 1.12 1.41              |
| 17.3 gm/cm <sup>3</sup>   | 1/2               | 1.26 <sub>2</sub>                             | 43.2 <sub>0</sub>                | 38.7 <sub>2</sub>                  | 0.81 <sub>6</sub>                       |                        |
| Be (QMV)  | 1                 | 0.90 <sub>7</sub>                             | 31.1 <sub>5</sub>                | 30.0 <sub>1</sub>                  | 1.45 <sub>9</sub>                       |                        |
| 1.84 gm/cm <sup>3</sup>   | 1/2               | 1.20 <sub>6</sub>                             | 41.3 <sub>5</sub>                | 37.5 <sub>5</sub>                  | 0.89 <sub>6</sub>                       |                        |
| Al <sub>2</sub> O <sub>3</sub> (>99 w/o)  | 1                 | 1.15 <sub>7</sub>                             | 39.6 <sub>0</sub>                | 36.4 <sub>4</sub>                  | 0.97 <sub>4</sub>                       |                        |
| 2.76 gm/cm <sup>3</sup>   | 1/2               | 1.41 <sub>8</sub>                             | 48.5                             | 41.6                               | 0.62 <sub>2</sub>                       |                        |
| Mo <sub>2</sub> C (95-96 w/o)   | 1                 | 0.95 <sub>8</sub>                             | 32.8 <sub>8</sub>                | 31.4 <sub>3</sub>                  | 1.34 <sub>6</sub>                       |                        |
| 9.57 gm/cm <sup>3</sup>   | 1/2               | 1.23 <sub>9</sub>                             | 42.4 <sub>6</sub>                | 38.2 <sub>5</sub>                  | 0.84 <sub>8</sub>                       |                        |
| Polythene   | 1                 | 1.01 <sub>4</sub>                             | 34.7 <sub>8</sub>                | 32.9 <sub>2</sub>                  | 1.23 <sub>2</sub>                       |                        |
| 0.921 gm/cm <sup>3</sup>  | 1/2               | 1.35 <sub>7</sub>                             | 46.4 <sub>2</sub>                | 40.5 <sub>6</sub>                  | 0.69 <sub>3</sub>                       |                        |
| 1/2 in. thick Be in<br>1/2 in. thick Fe   |                   | 1.00 <sub>4</sub>                             | 34.4 <sub>3</sub>                | 32.6 <sub>4</sub>                  | 1.25 <sub>3</sub>                       |                        |
| 1/2 in. thick Be in<br>1/2 in. thick Fe<br>but 1 in. Be in<br>1/2 in. Fe on one end |                   | 0.96 <sub>9</sub>                             | 33.2 <sub>6</sub>                | 31.7 <sub>1</sub>                  | 1.32 <sub>4</sub>                       |                        |

<sup>a</sup>Delayed critical masses,  $m_c$ , are normalized to standard Oy concentration (93.5 w/o) and density (18.8 gm/cm<sup>3</sup>).

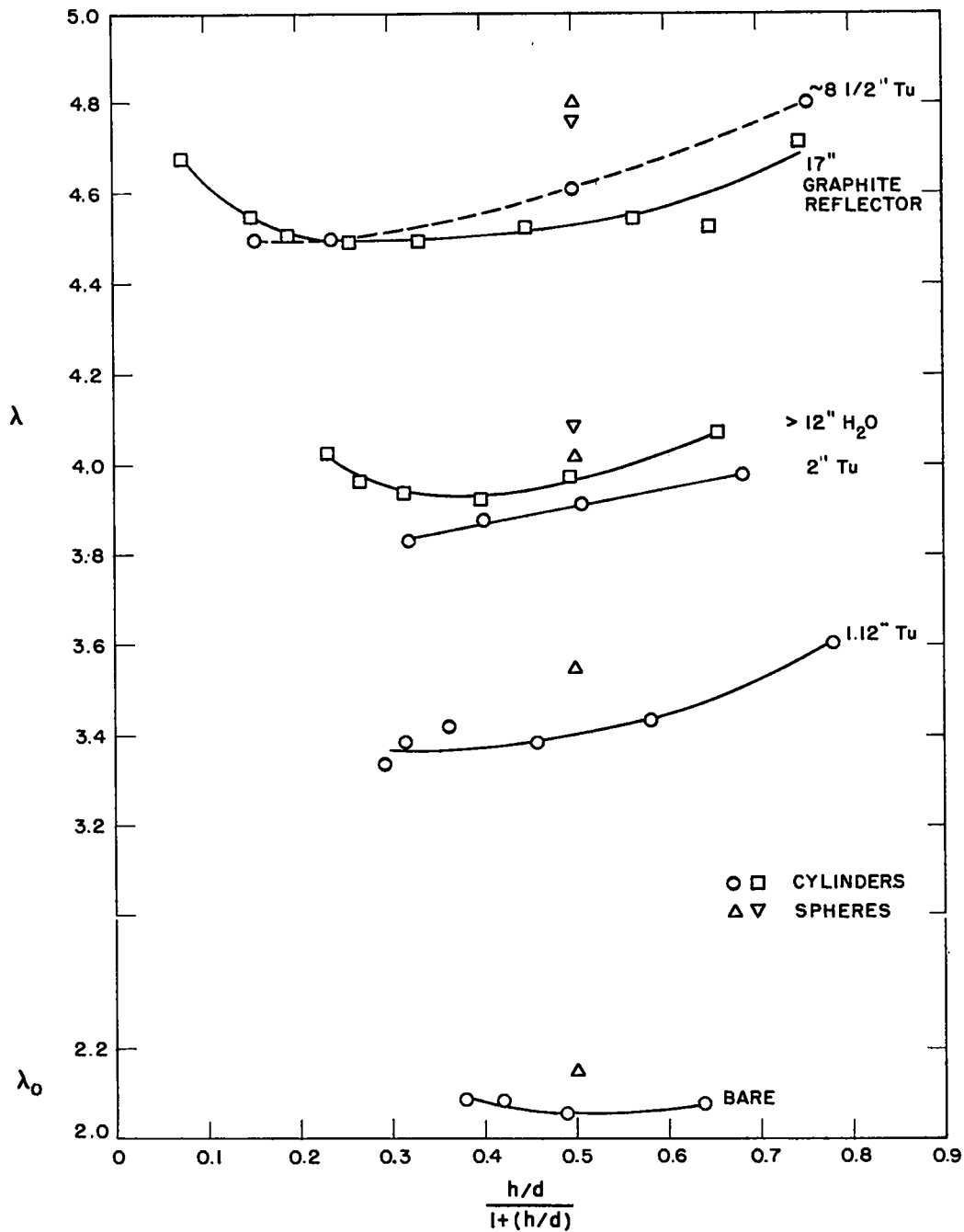

Fig. 4 Curve of effective extrapolation length  $\lambda$  vs.  $(h/d)/(1 + h/d)$  for several reflectors.  
 $\lambda_{os}(\text{sphere}) \equiv 2.15 \text{ cm.}$

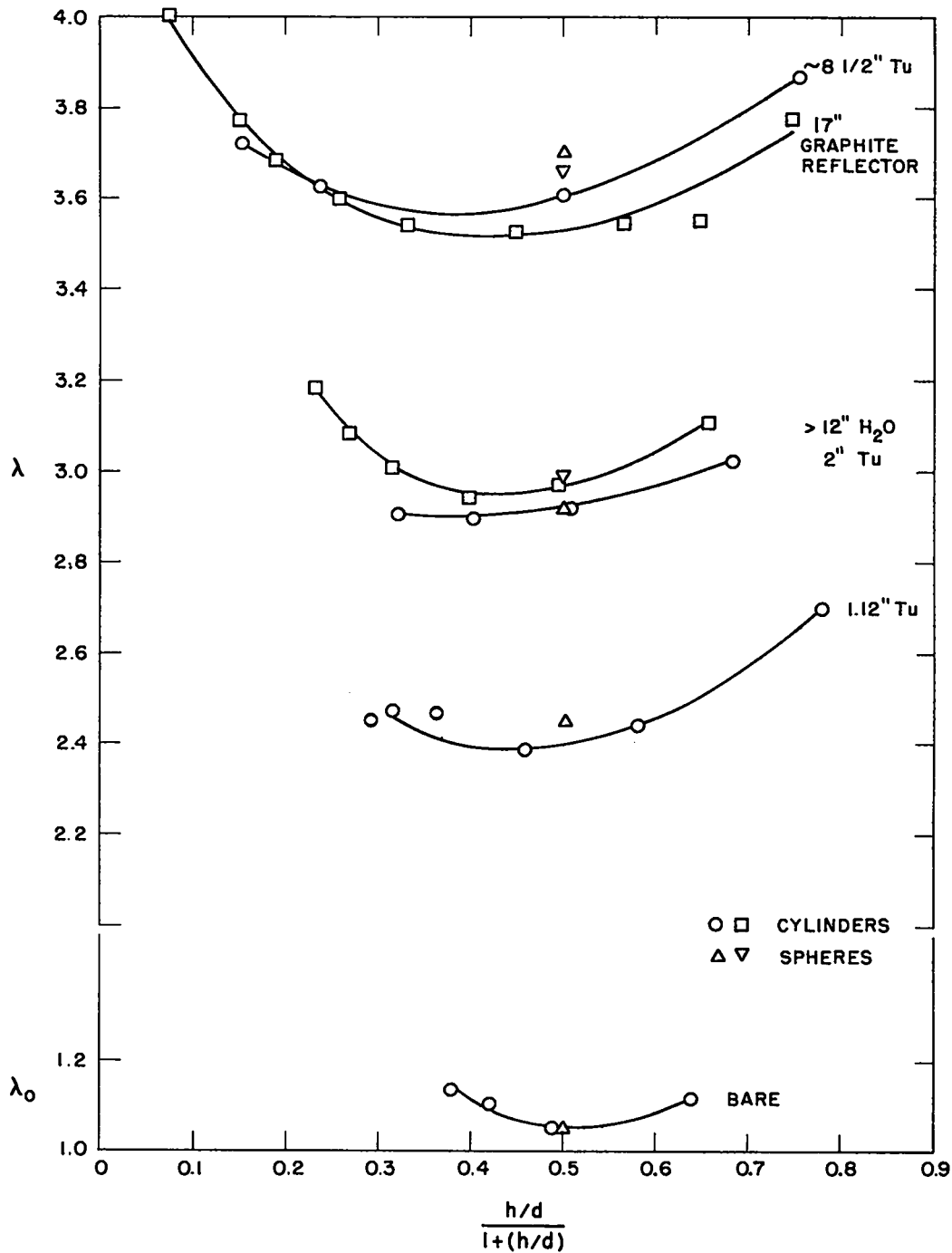

Fig. 5 Curve of  $\lambda$  vs.  $(h/d)/(1 + h/d)$  with  $\lambda_{OS}(\text{sphere}) \equiv 1.05$  cm.

where  $r_o = 8.71$  cm is the critical radius of the unreflected Oy sphere and  $\lambda_{os}$  the corresponding bare sphere extrapolation length ( $\cong 2.15$  cm from theory). The present cylinder critical mass data, together with Eq. 1, yield effective extrapolation lengths  $\lambda$  which with Fig. 4 or 5 give corresponding extrapolation lengths  $\lambda_s$  for the critical spheres with the same reflector thicknesses. The equivalent critical sphere radii (and masses) are then obtained from  $r = r_o + \lambda_{os} - \lambda_s$ , the reflector saving being  $r_o - r$ .\*

### 1.5.2 Interpretation of Reflector Savings in Terms of Scattering Cross Sections

The addition of a very thin reflector of material x around a fissionable core produces a reactivity gain proportional to  $[Nt \sigma(1 + f)]_x$ , where N is the nuclear density, t is the thickness,  $\sigma$  is a collision cross section here assumed to be the transport average, and f is the excess neutrons emitted per collision. The reflector saving  $[\Delta r]_x$  balancing this reactivity gain is then given by

$$[N \sigma(1 + f)]_{Oy} [\Delta r]_x = [Nt \sigma(1 + f)]_x \quad (2)$$

---

\*The cylinder-to-sphere conversions of these thin reflector systems were first computed (Los Alamos internal report by Group N-2, February 1955) on the assumption of shape-independent extrapolation lengths ( $\lambda \cong \lambda_s$  for cylinders and spheres reflected by same thicknesses of same material). That this assumption is inaccurate is clearly demonstrated by the critical mass data given in Fig. 4 or 5.

Equation 2 gives the cross section  $[\sigma(1 + f)]_x$  in terms of  $[\sigma(1 + f)]_{Oy}$ , the remaining parameters in the equation being known. Although the 1/2 and 1 in. thick reflectors do not satisfy the condition of being "very thin," the values of  $[\sigma(1 + f)]_x$  obtained from this equation for the two thicknesses  $t_x$  may be extrapolated to zero thickness. For example, applied to the Tu-reflected cylinders, the equation with  $[\sigma(1 + f)]_{Oy} = 7.0$  barns gives

$$[\sigma(1 + f)]_{Tu} = 3.65 \text{ barns [for } t(Tu) = 1 \text{ in.]}$$

$$[\sigma(1 + f)]_{Tu} = 4.53 \text{ barns [for } t(Tu) = 1/2 \text{ in.]}$$

$$[\sigma(1 + f)]_{Tu} = 5.41 \text{ barns [extrapolation to } t(Tu) = 0]$$

By using Tu rather than Oy as a standard material, Eq. 2 is replaced by

$$[\sigma(1 + f)]_x = \frac{[Nt \sigma(1 + f)]_{Tu} [\Delta r]_x}{[Nt]_x [\Delta r]_{Tu}} \quad (3)$$

Equation 3 with  $[\sigma(1 + f)]_{Tu} = 5.40$  barns gives, with the data of Table I, the  $[\sigma(1 + f)]_x$  values listed in Table III. These values, which are not extrapolated to zero thickness, are compared with corresponding transport cross sections deduced from reactivity contributions as functions of radius in the Topsy Oy-Tu and Godiva critical assemblies.

The failure of  $\sigma_{tr}(Mo)$  to agree with the value from Topsy replacement data (LA-1708) is unexplained. Otherwise,

TABLE III.  
CORRESPONDING RELATIVE TRANSPORT CROSS SECTIONS  
OF THE REFLECTOR MATERIALS

| Material<br>and Density  | Reflector<br>Thick-<br>ness,<br>in. | Reflector<br>Effect, <sup>a</sup><br>$\sigma(1+f) \sim \sigma_{tr}$<br>barns | $10^{-24}$<br><i>atoms</i><br>$\text{cm}^{-3}$<br>$N$ | $\sigma_{tr}$ from          |                            |
|--------------------------|-------------------------------------|--|---|-----------------------------|----------------------------|
|                          |                                     |  |   | LA-1708, <sup>b</sup> barns | Topsy $\Sigma_{tr}$ Godiva |
| Mg (FS-1)                | 1                                   | 2.48 ± 0.05  | .044  | 2.37                        | .104 --                    |
| 1.77 gm/cm <sup>3</sup>  | 1/2                                 | 2.73 ± 0.13  |   |                             |                            |
| Ti (96.5 w/o)            | 1                                   | 2.23 ± 0.02  | .057  | 2.16                        | .127 --                    |
| 4.50 gm/cm <sup>3</sup>  | 1/2                                 | 2.34 ± 0.10  |   |                             |                            |
| Al (2S)                  | 1                                   | 2.19 ± 0.02  | .0603   | 2.12                        | .132 2.14                  |
| 2.70 gm/cm <sup>3</sup>  | 1/2                                 | 2.27 ± 0.09  |   |                             |                            |
| Graphite (CS-312)        | 1                                   | 2.22 ± 0.02  | .084  | 2.13                        | .179 2.17                  |
| 1.67 gm/cm <sup>3</sup>  | 1/2                                 | 2.25 ± 0.03  |   |                             |                            |
| Fe (SAE 1020)            | 1                                   | 2.14 ± 0.02  | .084  | 2.29                        | .192 2.29                  |
| 7.78 gm/cm <sup>3</sup>  | 1/2                                 | 2.23 ± 0.03  |   |                             |                            |
| Ni (electrolytic)        | 1                                   | 2.52 ± 0.02  | .090  | 2.77                        | .250 2.65                  |
| 8.79 gm/cm <sup>3</sup>  | 1/2                                 | 2.64 ± 0.02  |   |                             |                            |
| Cu (99-99.5 w/o)         | 1                                   | 2.76 ± 0.02  | .084  | 2.68                        | .225 2.73                  |
| 8.87 gm/cm <sup>3</sup>  | 1/2                                 | 2.82 ± 0.02  |   |                             |                            |
| Co (reagent)             | 1                                   | 2.63 ± 0.02  | .089  | 2.73                        | .234 2.75                  |
| 8.72 gm/cm <sup>3</sup>  | 1/2                                 | 2.75 ± 0.02  |   |                             |                            |
| Mo (99.8 w/o)            | 1                                   | 3.61 ± 0.02  | .066  | 4.58                        | .303 --                    |
| 10.53 gm/cm <sup>3</sup> | 1/2                                 | 3.65 ± 0.02  |   |                             |                            |
| U (normal)               | 1                                   | 5.40 <sup>c</sup>  | .047  | 5.20 <sup>c</sup>           | .254 5.20 <sup>c</sup>     |
| 18.8 gm/cm <sup>3</sup>  | 1/2                                 | 5.40 <sup>c</sup>  |   |                             |                            |
| W (~91.3 w/o)            | 1                                   | 4.47 ± 0.03  | .057  | 4.40                        | .249 --                    |
| 17.3 gm/cm <sup>3</sup>  | 1/2                                 | 4.54 ± 0.03  |   |                             |                            |
| Be (QMV)                 | 1                                   | 2.32 ± 0.02 <sup>d</sup>   | .102  | 1.82                        | .186 2.17                  |
| 1.84 gm/cm <sup>3</sup>  | 1/2                                 | 2.30 ± 0.02 <sup>d</sup>   |   |                             |                            |

TABLE III (Continued)

| Material<br>and Density   | Reflector              | Reflector<br>Effect, <sup>a</sup><br>$\sigma(1+f) \sim \sigma_{tr}$<br>barns | $\sigma_{tr}$ from          |       |        |
|---|------------------------|--|-----------------------------|-------|--------|
|   | Thick-<br>ness,<br>in. |  | LA-1708, <sup>b</sup> barns | Topsy | Godiva |
| Al <sub>2</sub> O <sub>3</sub> (>99 w/o)<br>2.76 gm/cm <sup>3</sup> | 1                      | 11.7 ± 0.10 <sup>e</sup>   | 10.84                       | --    |        |
|   | 1/2                    | 12.0 ± 0.10 <sup>e</sup>   |                             |       |        |
| Mo <sub>2</sub> C (95-96 w/o)<br>9.57 gm/cm <sup>3</sup>            | 1                      | 9.32 ± 0.04 <sup>f</sup>   | 11.29                       | --    |        |
|   | 1/2                    | 5.01 ± 0.04 <sup>f</sup>   |                             |       |        |
| Polythene<br>0.921 gm/cm <sup>3</sup>                               | 1                      | 6.09 ± 0.05  |                             |       |        |
|   | 1/2                    | 5.53 ± 0.05  |                             |       |        |

<sup>a</sup>Impurities and additives ignored.

<sup>b</sup>L. B. Engle, G. E. Hansen, and H. C. Paxton, Material Replacement Measurements in Topsy and Godiva Assemblies, Los Alamos Scientific Laboratory Report LA-1708, July 1954.

<sup>c</sup>Cross sections are normalized to these values.

<sup>d</sup>Effect of plural scattering is uncertain.

<sup>e</sup>Applies to "molecule" Al<sub>2</sub>O<sub>3</sub>.

<sup>f</sup>Applies to "molecule" Mo<sub>2</sub>C.



the values obtained from the thin reflector data and the reactivity coefficient data agree within 5% except for Be, in which case multiple scattering may complicate the interpretation of reflecting effectiveness.

## 2. CRITICAL MASS MEASUREMENTS OF O<sub>2</sub> SPHERES IN 2 AND 4 IN. THICK REFLECTORS

Critical masses of O<sub>2</sub> spheres in ~2 and ~4 in. thick spherical reflectors of W alloy, Fe, Ni, Ni-silver, Cu, Zn, Th, Be, BeO, C, and Tu were measured at the Pajarito remote-control laboratory. These critical masses were converted to the standard O<sub>2</sub> concentration (93.5%) and density (18.8 gm/cm<sup>3</sup>), and critical mass vs. reflector thickness curves were obtained for these reflector materials.

### 2.1 Facilities

#### 2.1.1 Assembly Machine

The Comet universal machine was utilized. The stainless steel diaphragm described in Section 1.1.1 was removed and a steel A-frame with an attached hydraulic cylinder was secured to the Comet vertical supports. A hemisphere of the reflector material was screwed to the hydraulic piston. The other hemisphere containing the sphere of O<sub>2</sub> was fixed to the platen adapter on top of the hydraulic ram. Figure 6 is a schematic of a typical assembly.

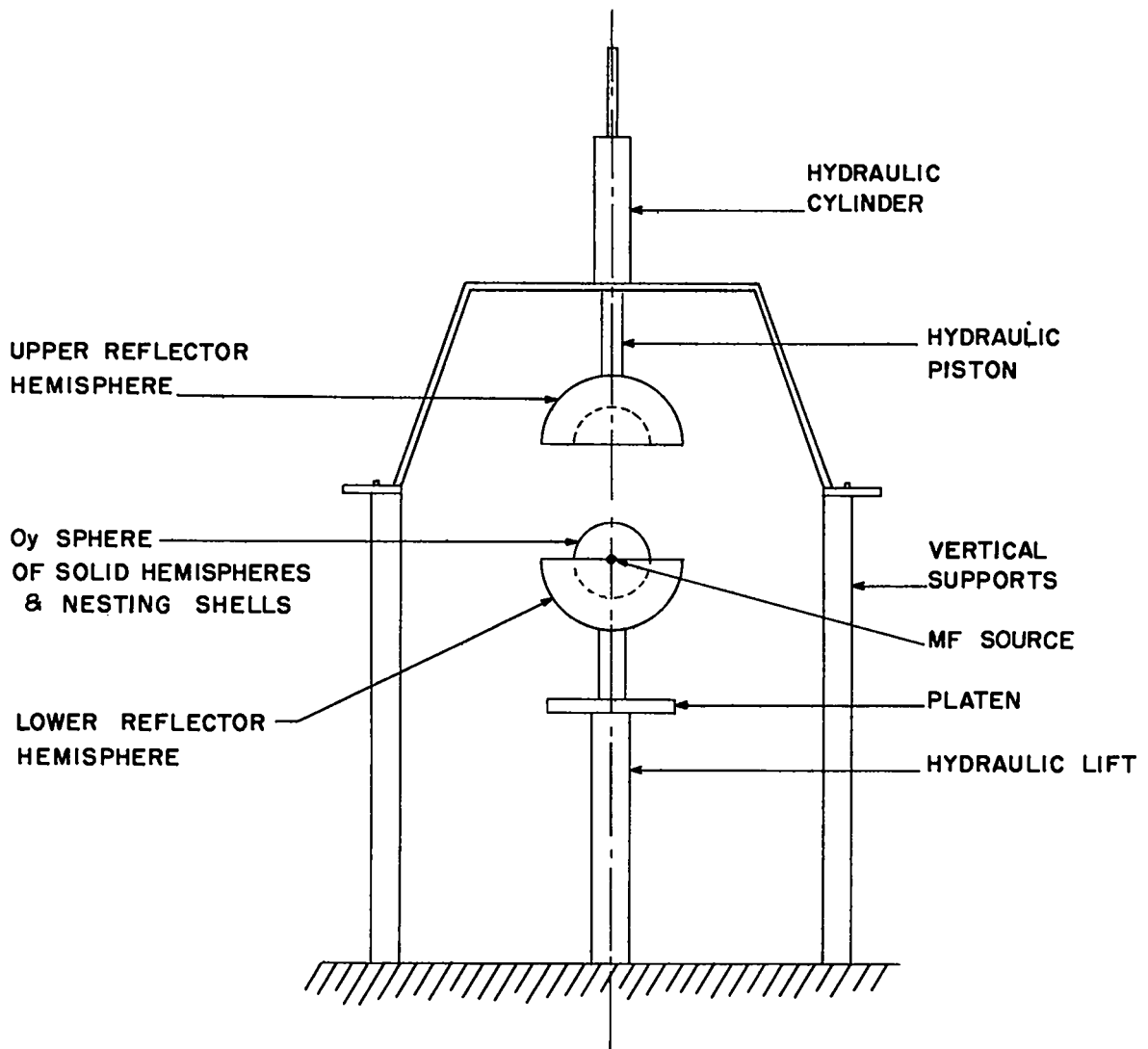

Fig. 6 Schematic of Oy sphere-reflector test setup on Comet.

### 2.1.2 Fissile Material

The Oy for this series of measurements was in the form of solid hemispheres and nesting shells of Oy. The hemispheres contained a central source cavity large enough to accommodate the mock-fission source.

These pieces were duplicated in Tu.

### 2.1.3 Reflector Material

Spherical shells ~2 and ~4 in. thick of the reflector material to be investigated were fabricated in sizes expected to yield high multiplications when encasing varying thicknesses (masses) of the Oy sphere and nesting shells. Figure 7 is a photograph of typical 2 and 4 in. thick reflectors.

### 2.1.4 Neutron Source and Counters

A mock-fission neutron source was centered in the Oy sphere for all tests. Four boron-lined neutron counters, in long-counter geometries, monitored the neutron leakage.

## 2.2 Neutron Multiplication

The neutron multiplication procedure was the same as described in Section 1.2.

## 2.3 Safety

Throughout the tests on the Comet, three safety monitors placed at varying distances from the assembly were used.

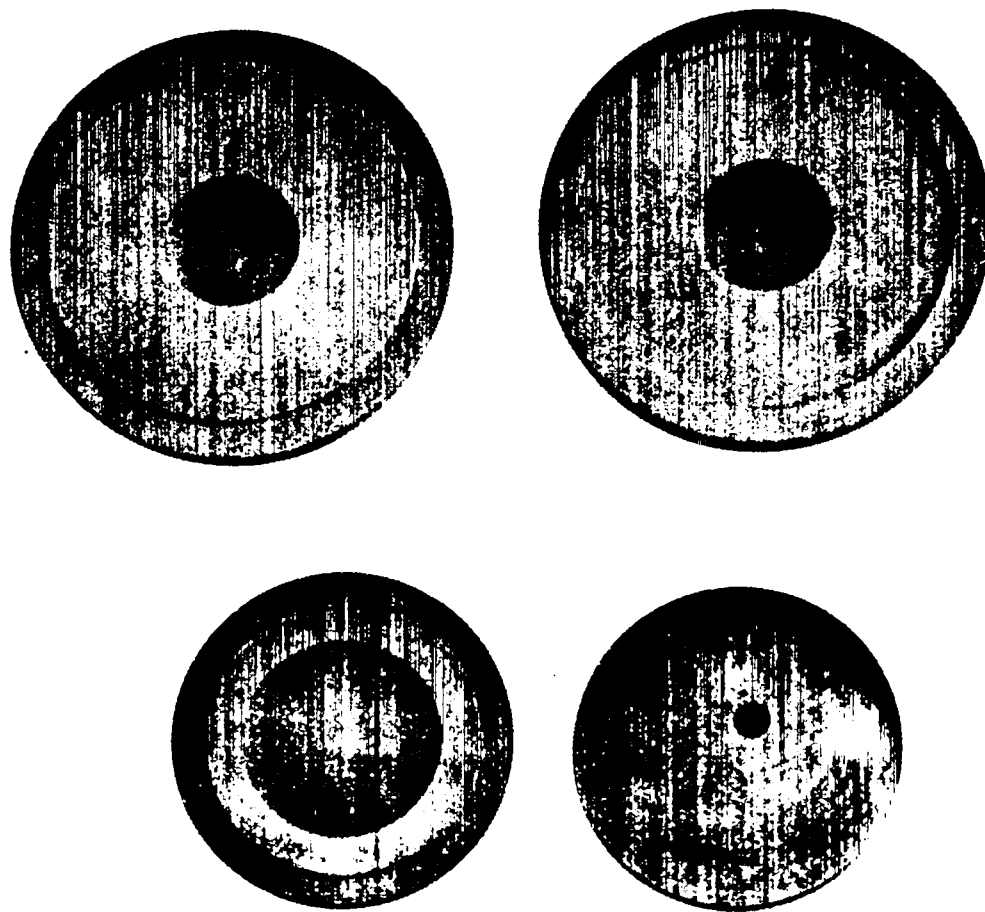

Fig. 7 Photograph of typical 2 and 4 in. thick reflectors.

Any one of these monitors would separate the active material by dropping the ram and raising the hydraulic piston if the neutron leakage exceeded a predetermined level.

#### 2.4 Procedure

The experimental setup is shown in Fig. 6. The top reflector on the hydraulic piston was lowered before the ram could be raised. The mating lower hemispherical reflector containing the Oy sphere located on the hydraulic ram was raised in preset steps toward the top reflector. A progressive plot of  $1/M$  vs. gap (distance between parting surfaces of top and bottom reflectors) permitted one to close the assembly safely or to leave a sufficient gap in cases of higher multiplications. With the Oy-reflector assembly closed, a multiplication value was determined. Different values were determined by varying the mass of the Oy sphere. These values were plotted on a  $1/M$  vs. Oy mass curve and permitted an extrapolation to delayed critical for the Oy-reflector configuration under investigation.

#### 2.5 Results

Results of these experimental measurements\* are recorded in Table IV after having been corrected to the standard Oy concentration and density.

---

\*H. C. Paxton, Los Alamos internal report, March 8, 1952.

TABLE IV  
CRITICAL MASSES OF SPHERICAL Oy<sup>a</sup> IN ~2 AND ~4 IN. THICK SPHERICAL REFLECTORS

| Core Shape          | Reflector                         |                             | Approximate Values <sup>b</sup> of |                   |                |           |
|---------------------|-----------------------------------|-----------------------------|------------------------------------|-------------------|----------------|-----------|
|                     | Material                          | Density, gm/cm <sup>3</sup> | Shape                              | $m_c$ , kg        | $m_{max}$ , kg | $M_{max}$ |
| Sphere <sup>c</sup> | W alloy<br>90% W, 7% Ni,<br>3% Cu | 17.39                       | Sphere,<br>2.00 in.<br>thick       | 25.8±0.2          |                | 159       |
| Sphere <sup>c</sup> | W alloy<br>(against Oy)           | 17.39                       | Sphere,<br>2.00 in.<br>thick       | 22.5±0.5          | 19.5           | 20        |
|                     | Cast iron<br>(outside<br>W alloy) | 7.16                        | Sphere,<br>2.00 in.<br>thick       |                   |                |           |
| Sphere              | W alloy<br>90% W, 7% Ni,<br>3% Cu | 17.39                       | Sphere,<br>4.00 in.<br>thick       | 20.8 <sup>d</sup> | 19.5           | 44        |
| Sphere              | Cast iron                         | 7.16                        | Sphere,<br>4.00 in.<br>thick       | 27.1±0.2          |                | 143       |
| Sphere              | Cast iron                         | 7.16                        | Sphere,<br>2.00 in.<br>thick       | 31.3±0.3          | 30.3           | 59        |
| Sphere              | Ni                                | 8.35                        | Sphere,<br>2.00 in.<br>thick       | 28.7 <sup>d</sup> | 27.6           | 41.8      |

TABLE IV (Continued)

| Core Shape | Reflector                                     |                                |                               | Approximate Values <sup>b</sup> of |                |           |
|------------|---|--------------------------------|-------------------------------|------------------------------------|----------------|-----------|
|            | Material                                      | Density,<br>gm/cm <sup>3</sup> | Shape                         | $m_c$ , kg                         | $m_{max}$ , kg | $M_{max}$ |
| Sphere     | Ni-silver<br>40% Cu, 32% Ni,<br>28% Zn by wt. | 8.55                           | Sphere,<br>2.02 in.<br>thick  | 27.5±0.3 <sup>d</sup>              | 25.9           | 46.0      |
| Sphere     | Ni-silver<br>40% Cu, 32% Ni,<br>28% Zn by wt. | 8.55                           | Sphere,<br>1.88 in.<br>thick  | 27.7 <sup>d</sup>                  | 27.6           | 89        |
| Sphere     | Cu  | 8.88                           | Sphere,<br>4.175 in.<br>thick | 22.1±0.2 <sup>e</sup>              |                | 141       |
| Sphere     | Cu  | 8.88                           | Sphere,<br>2.00 in.<br>thick  | 27.2±0.2 <sup>d,f</sup>            |                | 118       |
| Sphere     | Zn  | 7.04                           | Sphere,<br>4.075 in.<br>thick | 26.6±0.3 <sup>d</sup>              | 25.5           | 46        |
| Sphere     | Zn  | 7.04                           | Sphere,<br>2.00 in.<br>thick  | 31.9 <sup>d</sup>                  | 30.3           | 52        |
| Sphere     | Th  | 11.48                          | Sphere,<br>1.81 in.<br>thick  | 36.7±0.2 <sup>d</sup>              | 36.4           | 162       |
| Sphere     | Be  | 1.84                           | Sphere,<br>4.64 in.<br>thick  | 13.8±0.2                           |                | 143       |

TABLE IV (Continued)

| Core Shape                       | Reflector            |                                |   | Approximate Values <sup>b</sup> of |                |           |
|----------------------------------|----------------------|--------------------------------|---|------------------------------------|----------------|-----------|
|                                  | Material             | Density,<br>gm/cm <sup>3</sup> | Shape   | $m_c$ , kg                         | $m_{max}$ , kg | $M_{max}$ |
| Sphere                           | Be                   | 1.84                           | Sphere,<br>1.85 in.<br>thick                    | 23.3±0.2                           |                | 100       |
| Sphere                           | Be                   | 1.84                           | Sphere,<br>1.89 in.<br>thick                    | ~23.1                              |                | 24        |
| Pseudo-<br>sphere <sup>g-i</sup> | BeO                  | 2.69                           | Pseudosphere, <sup>g</sup><br>3.5 in.<br>thick  | 17.6±0.2                           |                | 105       |
| Pseudo-<br>sphere <sup>g-i</sup> | BeO                  | 2.69                           | Pseudosphere, <sup>g</sup><br>2.35 in.<br>thick | 21.0±0.2                           |                | 85        |
| Sphere                           | Graphite<br>(CS-312) | 1.69                           | Sphere,<br>2 in.<br>thick                       | 31.5±0.3                           |                | 58        |
| Sphere                           | Graphite<br>(CS-312) | 1.69                           | Sphere,<br>4 in.<br>thick                       | 25.9±0.2                           |                | 150       |
| Sphere, <sup>i</sup><br>solid    | Tu                   | ~19.0                          | Sphere,<br>3.925 in.<br>thick                   | 19.83±0.5%                         |                | 167       |
| Sphere, <sup>j</sup><br>solid    | Tu                   | ~19.0                          | Sphere,<br>3.525 in.<br>thick                   | 20.6±1%                            |                | 53        |



TABLE IV (Continued)

| Core Shape      | Reflector |                             | Approximate Values <sup>b</sup> of |            |                |           |
|-----------------|-----------|-----------------------------|------------------------------------|------------|----------------|-----------|
|                 | Material  | Density, gm/cm <sup>3</sup> | Shape                              | $m_c$ , kg | $m_{max}$ , kg | $M_{max}$ |
| Sphere, solid j | Tu        | ~19.0                       | Sphere, 1.76 in. thick             | 26.6±0.5%  |                | 141       |
| Sphere, solid j | Tu        | ~19.0                       | Sphere, 0.695 in. thick            | 36.3±0.5%  |                | 156       |

- a. Standard Oy concentration (93.5 w/o) and density (18.8 gm/cm<sup>3</sup>).
- b. Symbols are: m, mass;  $m_c$ , delayed critical mass; M, central source multiplication.
- c. Central source cavity 0.375 in. diameter x 0.45 in.
- d. From single point, using  $\Delta(1/M)/\Delta(r/r_c) = 1.15$ .
- e.  $m_c$  increased 0.3 kg with 0.83 in. diameter central cavity (-84 gm Oy).
- f.  $m_c$  increased 0.5 kg with 0.83 in. diameter central cavity (-84 gm Oy).
- g. 1/2 in. cubic units.
- h. Central source cavity 0.4 in. diameter x 0.46 in.
- i. Measurement not obtained in this series but included for completeness.
- j. Corrected for effect of central source cavity (per gm central Oy,  $\Delta(1/M) \sim 6 \times 10^{-5}$  for 0.7 in. thick Tu to  $\sim 7 \times 10^{-5}$  for 3.9 in. thick Tu).

Figures 8, 9, and 10 are curves of  $m_c(Oy)$  vs. thickness of reflectors for those reflectors for which more than two thickness points were available.

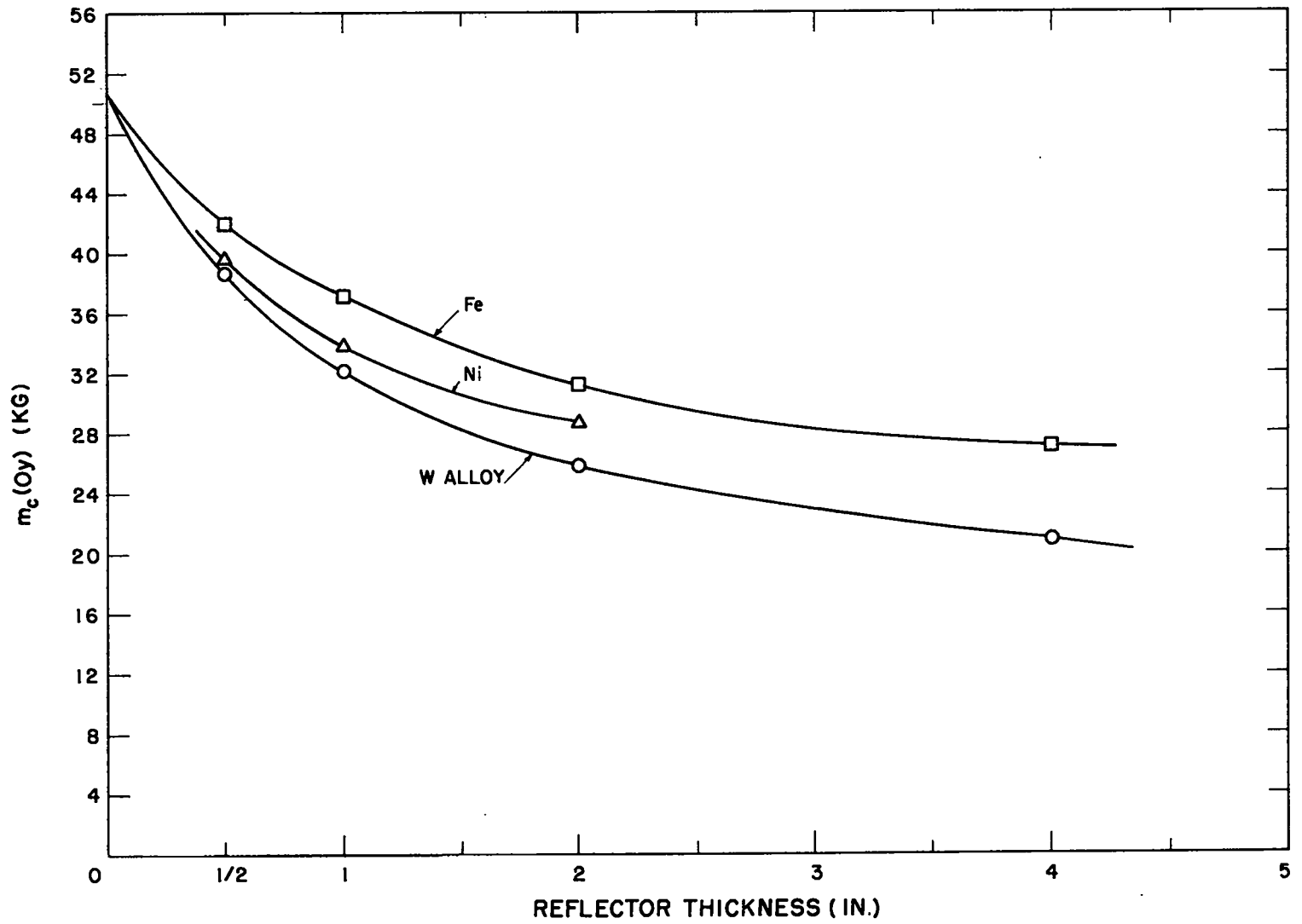

Fig. 8 Plot of  $m_c(Oy)$  vs. reflector thickness for Fe, Ni, and W alloy.

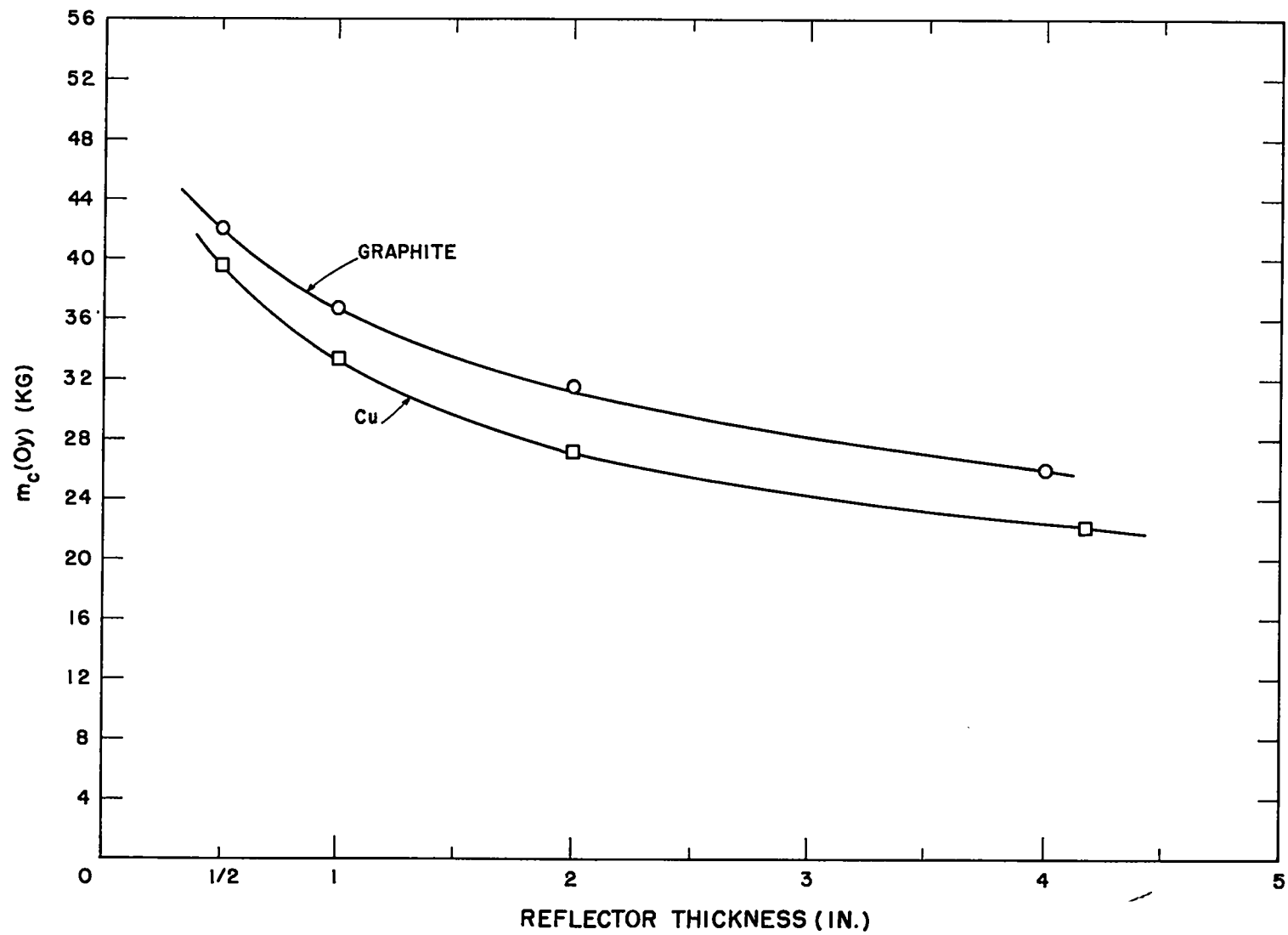

Fig. 9 Plot of  $m_c(Oy)$  vs. reflector thickness for Cu and graphite.

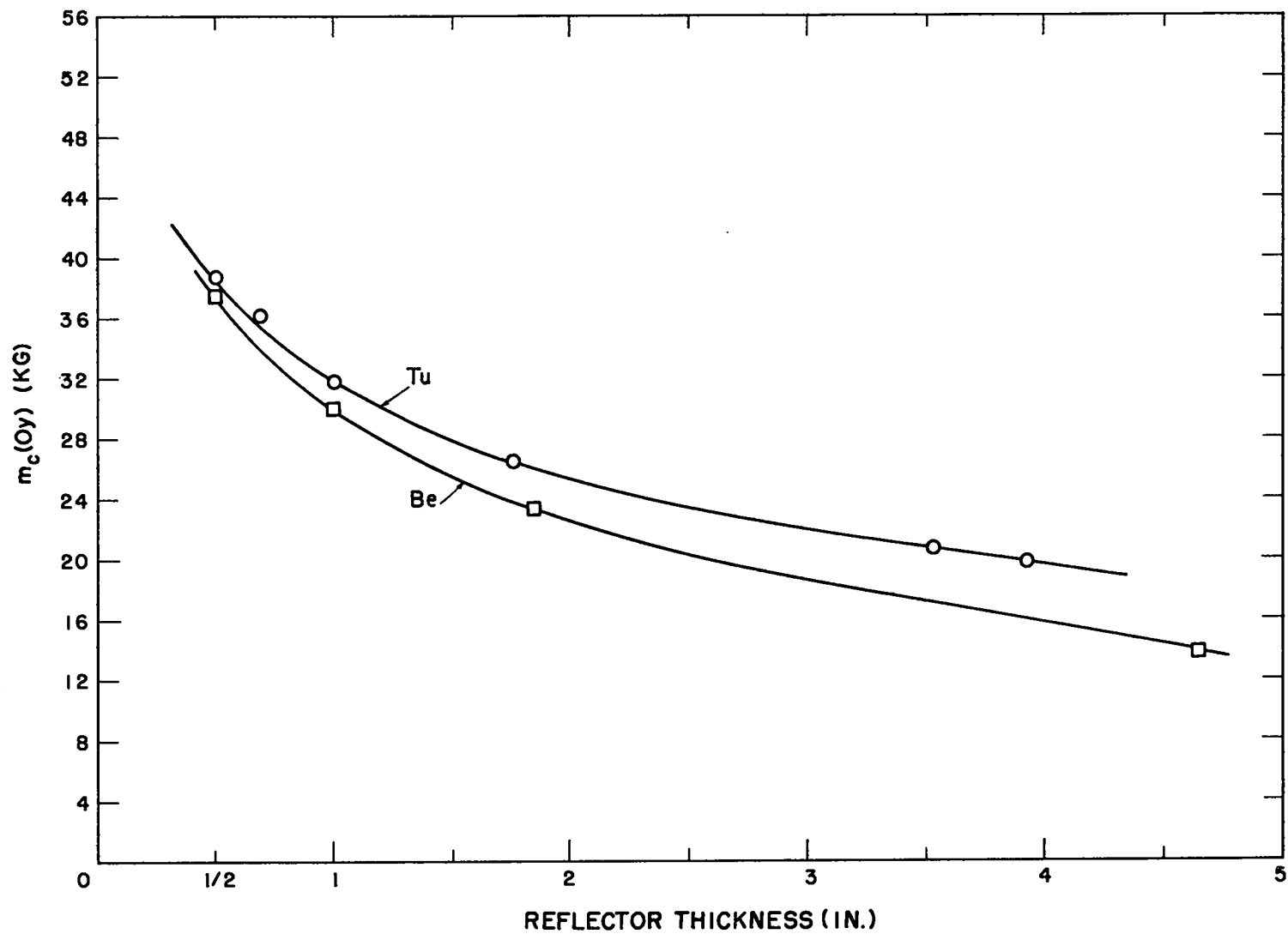

Fig. 10 Plot of  $m_c(Oy)$  vs. reflector thickness for Be and Tu.