

LA--1129

C. 3

CIC-14 REPORT COLLECTION
**REPRODUCTION
COPY**

LOS ALAMOS SCIENTIFIC LABORATORY

OF THE

UNIVERSITY OF CALIFORNIA

CONTRACT W-7405-ENG. 36 WITH

U. S. ATOMIC ENERGY COMMISSION

LOS ALAMOS NATIONAL LABORATORY

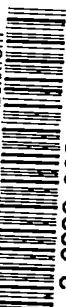

3 9338 00310 7355

JAN 4 - 1951

INSTRUMENTATION

PROJECT DISTRIBUTION

Los Alamos	20
Argonne National Laboratory	8
Armed Forces Special Weapons Project	1
Atomic Energy Commission, Washington	3
Battelle Memorial Institute	1
Brush Beryllium Company	1
Brookhaven National Laboratory	4
Bureau of Medicine and Surgery	1
Bureau of Ships	1
Carbide and Carbon Chemicals Division (K-25 Plant)	4
Columbia University (J. R. Dunning)	1
Columbia University (G. Failla)	1
Dow Chemical Company	1
General Electric, Richland	6
Idaho Operations Office	4
Iowa State College	2
Kansas City Operations Branch	1
Kellex Corporation	1
Kirtland Air Force Base	1
Knolls Atomic Power Laboratory	4
Mallinckrodt Chemical Works	1
Massachusetts Institute of Technology (A. Gaudin)	1
Massachusetts Institute of Technology (A. R. Kaufmann)	1
Mound Laboratory	3
National Advisory Committee for Aeronautics	1
National Bureau of Standards (R. D. Huntoon)	1
Naval Medical Research Institute	1
Naval Radiological Defense Laboratory	2
New Brunswick Laboratory	1
New York Operations Office	3
North American Aviation, Inc.	2
Oak Ridge National Laboratory (X-10 Site)	8
Oak Ridge National Laboratory (Y-12 Site)	4
Patent Branch, Washington	4
PRAND Corporation	1
Sandia Corporation	1
Santa Fe Operations Office	1
Technical Information Service, Oak Ridge	1
USAF, NEPA Office	75
U. S. Geological Survey (T. B. Nolan)	2
U. S. Public Health Service	2
University of California at Los Angeles	2
University of California Radiation Laboratory	3

LOS ALAMOS NATL. LAB. LIBS.



3 9338 00310 7355

43
200
71

INSTRUMENTATION

PROJECT DISTRIBUTION

University of Rochester	2
University of Washington	1
Western Reserve University	1
Westinghouse Electric Corporation	4

SUPPLEMENTARY DISTRIBUTION

Atomic Energy Project, Chalk River	4
Chief of Naval Research	1
H. K. Ferguson Company	1
Harshaw Chemical Corporation	1
Isotopes Division (Mr. McCormick)	1
Library of Congress, Acquisition Department (J. W. Corra)	2
National Bureau of Standards (Library)	1
National Research Council, Ottawa	1
Naval Research Laboratory	1
Nevis Cyclotron Laboratories	1
Nucleonics	1
Oak Ridge Institute of Nuclear Studies	2
United Kingdom Scientific Mission (M. Greenhill)	10
USAF, Air Surgeon (Col. A. P. Gagge)	1
USAF, Eglin Air Force Base (Technical Library)	1
USAF, Wright-Patterson Air Force Base (Rodney Nudenberg)	1
USAF, Wright-Patterson Air Force Base (CADO)	5
U. S. Army, Army Field Forces (Captain James Kerr)	1
U. S. Army, Army Medical Service Graduate School (Col. W. S. Stone)	1
U. S. Army, Atomic Energy Branch (Lt. Col. A. W. Betts)	1
U. S. Army, Director of Operations Research (Dr. Ellis Johnson)	1
U. S. Army, Office of the Chief Signal Officer (Curtis T. Clayton thru Major George C. Hunt)	2
U. S. Army, Technical Command (Col. J. H. Rothschild Attn: Technical Library)	3
UT-AEC Agricultural Research Program (Charles S. Hobbs)	1

LOS ALAMOS SCIENTIFIC LABORATORY
of
THE UNIVERSITY OF CALIFORNIA

July 7, 1950

LA-1129

THE USE OF URANIUM AS A PUMP FOR HYDROGEN



Work done by:

R. C. Cornelius
W. J. Masilun
S. E. Stephanou

Report written by:

R. C. Cornelius
S. E. Stephanou

INSTRUMENTATION

The Use of Uranium as a Pump for Hydrogen

ABSTRACT

The use of uranium as an absorbing medium for hydrogen in a Zinn-type ion source was studied for the purpose of investigating the extent of recovery of hydrogen and the resulting decrease in pressure in the accelerating tube attached to the ion-source. With various geometries a maximum recovery of about 70% was obtained, and accelerating tube pressures were decreased by a factor of two or more, depending upon the flow rate of hydrogen into the ion source. While the results obtained are only preliminary, this method may have applications under actual operating conditions of the ion source.

Introduction

The rapid absorption of hydrogen and deuterium by activated uranium has been extensively reported and described in the literature in recent years.^{1,2} The use of uranium as a pump in an ion source where hydrogen or one of its isotopes is employed could offer certain mechanical and other advantages if the absorption of the hydrogen was sufficiently rapid. It is the purpose of this report to give experimental data and calculations showing that such a scheme can be made to give up to about 70% recovery and decrease accelerating tube pressures by a factor of two or more, depending upon the ion source pressure and the geometry of the system.

A circulating diffusion pump system recovering hydrogen and feeding it back to the ion source was also tested under conditions similar to those employed with the U pump and its recovery of hydrogen also determined, assuming that no appreciable amount of the gas is lost by absorption in the oil of the pumps.

Experimental

The apparatus employed (shown diagrammatically in Fig. 1) consisted of a Zinn-type ion source to which an accelerating tube was attached. The two stainless steel pots in the uranium pumping system

¹(a) F. H. Spedding, et al., *Nucleonics*, 4, 4 (1949). An excellent bibliography is given.

(b) *ibid*, p. 17.

²J. E. Burke and C. S. Smith, *J. Am. Chem. Soc.*, 69, 2500 (1947).

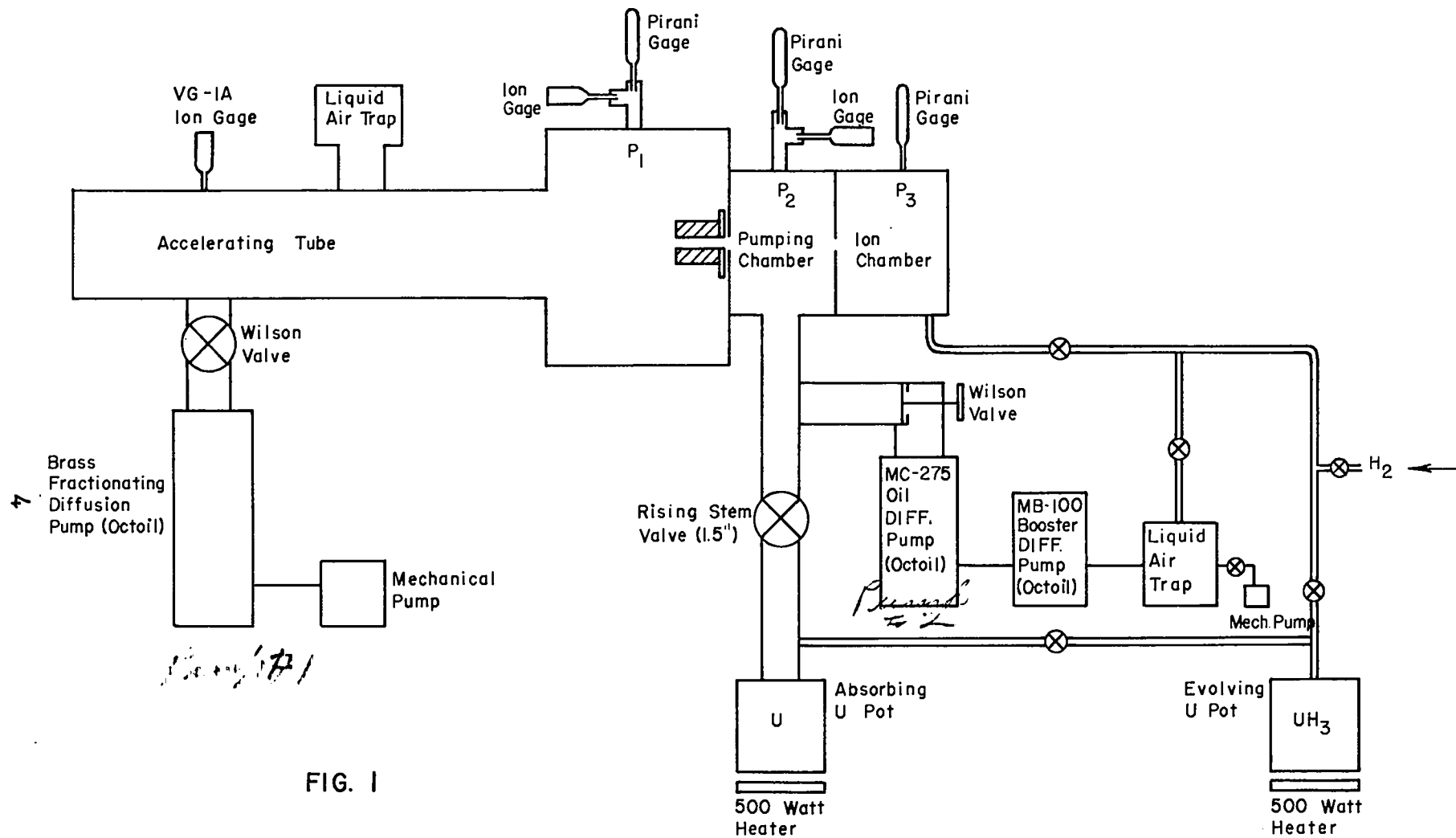

FIG. 1

each contained 100 grams of the cleaned metal in the form of turnings. The uranium was activated by passing in hydrogen under pressure and driving off the gas by heating to high temperature. The activation was increased by repeatedly cycling the hydrogen from one pot to the other; the absorbing pot was maintained at room temperature while the evolving pot was heated. It was found that the rate of absorption of hydrogen to give uranium hydride varied with the treatment of the uranium before the absorption process. The best results were obtained when the metal was stripped of all hydrogen and absorbed gases by heating to over 600°C in vacuo. The absorbing uranium was reactivated in this manner before each experiment in order to insure reliable results.

The procedure for the uranium pump experiments consisted of heating the evolving pot so that hydrogen entered the ion source and passed into the pumping chamber where it could either be absorbed by the activated uranium or be pumped out by the brass diffusion pump at the other end of the accelerating tube. It was found that maintaining the temperature of the evolving pot between 100-170°C gave the desired range of ion source pressures. The absorbing pot was maintained at temperatures slightly above room temperature (not greater than 65°C) to insure as rapid a reaction rate as possible. The theoretical dissociation pressure of hydrogen over uranium hydride, calculated from the equation,

$$\log p = \frac{-4500}{T} + 9.28^{1a}$$

where T is in degrees Kelvin and p in mm. of mercury, is about 10^{-6} mm. at 20°C and 10^{-3} mm. at 90°C . Pressure readings were taken in the various portions of the apparatus for different rates of flow of hydrogen into the ion source, that is, for different ion source pressures. The experiment was repeated and pressure readings taken for the same ion source pressures but with the absorbing uranium pot out of the system. From the measurements of the two experiments, the fraction of hydrogen X recovered can be calculated by means of the expression,

$$(1) \quad *X = \frac{1}{1 + \frac{P_2'/P_2(1 - P_2/P_3)}{1 - P_2'/P_2}}, \text{ where } P_2'/P_2 \text{ is the ratio of}$$

the pressures in the pumping chamber with and without the absorbing uranium pot in the system, P_2 is the pumping chamber pressure and P_3 the ion source pressure. Primed values refer to conditions when the absorbing uranium pot is included in the system. The ratio P_2'/P_2 could also be replaced by the ratio P_3'/P_3 where P_3 is the pressure in the accelerating tube near the pumping chamber, as measured by a VG-1A ion gage (DPI model). More precise ratios were obtained by the substitution of ion gage readings and values of the fraction of hydrogen recovered calculated. This substitution is valid inasmuch as the pumping speed of the diffusion pump is constant over most of the range of throat pressures measured.³ In the derivation of this expression

³R. B. Setlow, Rev. Sci. Instr. 19, 533 (1948).

*See Appendix I.

which diffusion pump?
6 P P 1 pump

Which assumption A or B?

a material balance for the steady state was made around the pumping chamber under the two conditions, with and without the uranium pot. It was assumed^A that at the pressures obtained the flow of gas was molecular, and therefore the rate of flow (moles/sec.) through each connecting passage was directly proportional to the pressure difference across it. The product aP (a is radius of tube in cm. and P is the average pressure in microns) is less than $100 L_1$ (L_1 is the mean free path of hydrogen at 1 micron pressure). According to Dushman, this may be taken as a criterion^B for over 95% molecular flow.⁴ Inasmuch as this assumption is in error the results are also in error in addition to the experimental error involved in the pressure readings.

What does this error amount to? What can you do about it?
JH

The identical procedure was employed for the circulating diffusion pumps and the fraction of hydrogen recovered calculated for different ion source pressures.

The original purpose of the experiments was to determine whether a uranium pump could be used to advantage in an ion source system, and what effects on accelerating tube pressures could be expected. As the work progressed the qualitative results proved encouraging and it became evident that a more quantitative treatment was necessary in order to determine the efficiency of the pump in recovering hydrogen. Since time did not permit the redesigning and rebuilding of the apparatus for the purpose of making direct experimental measurements of the

See p. 24

⁴S. Dushman, "Scientific Foundations of Vacuum Technique", p. 114, John Wiley and Sons (1949).

What constitutes desirable effects?
Lower pressures, higher pressures, more constant pressures or what else?
JH

amount of hydrogen transferred from one pot to the other, the above method of calculation was developed for use with the data available.

Results

The experimental results are shown graphically in Figs. 2, 3 and 4. In testing the uranium pump two sets of experiments were performed, one in which the tube between the pumping chamber and the accelerating tube was 1/8 inch in diameter and 1 1/4 inches long, and the other in which the connection consisted of a tube 1/8 inch in diameter and 1 1/8 inches long next to an orifice 1/16 inch in diameter and 1/8 inch long. The ratio of the total impedances in the two cases, using the expression derived by Clausing,⁵ is 1.83 for an ion source pressure of 0.12 mm.⁶ From the measured efficiency, 0.50, of the uranium pump when the 1/8 inch orifice was used and the ratio of impedances, the efficiency for the 1/16 inch orifice was calculated to be 0.65.⁷ This calculated value was in fair agreement with the experimentally determined efficiency of 0.70 at an ion source pressure of 0.12 mm.⁶

Discussion

From the graphs it is evident that the circulating pump gave the best recovery of hydrogen and the lowest accelerating tube pressures

⁵ibid., p. 96. See Appendix II.

⁶Multiply by 0.45 for true hydrogen pressure.

⁷See Appendix II.

*no evidence given
for this step*

*The two curves
in fig 3 cross
at 0.11 mm !!*

for ion source pressures of less than .07 mm. However, the efficiency of the circulating diffusion pump system decreases with increasing ion source pressure so that at relatively high ion source pressures the uranium pump is superior by at least a factor of two in the case of the 1/16 inch orifice. The performance of the uranium pump appears to be fairly constant over the range of ion source pressures 0.06 to 0.12 mm.⁶

The error in the measurements, providing the theory is adequate, is estimated to be of the order of $\pm 10\%$. The curves were drawn through the points obtained from Pirani and Ion Gage readings.

In the uranium experiments the absorbing uranium was located about two feet from the pumping chamber, due to the pipe connections necessary for the circulating pump system. It seems probable that moving of the uranium pot closer to the pumping chamber might improve the results.

In conclusion mention should be made of the fact that the experiments described in this report did not involve more than four hours' continuous operation of the uranium pump. It is likely that operation of the pump for longer periods will cause the upper layers of the metal to become saturated and the hydrogen will have to diffuse to lower layers. As a result the efficiency of the pump might be expected to decrease with time of use.

*See
fig 29*

Fig. 2

Comparison of accelerating tube pressures near pumping chamber with and without U pump using a 1/16" orifice between the pumping chamber and the accelerating tube.

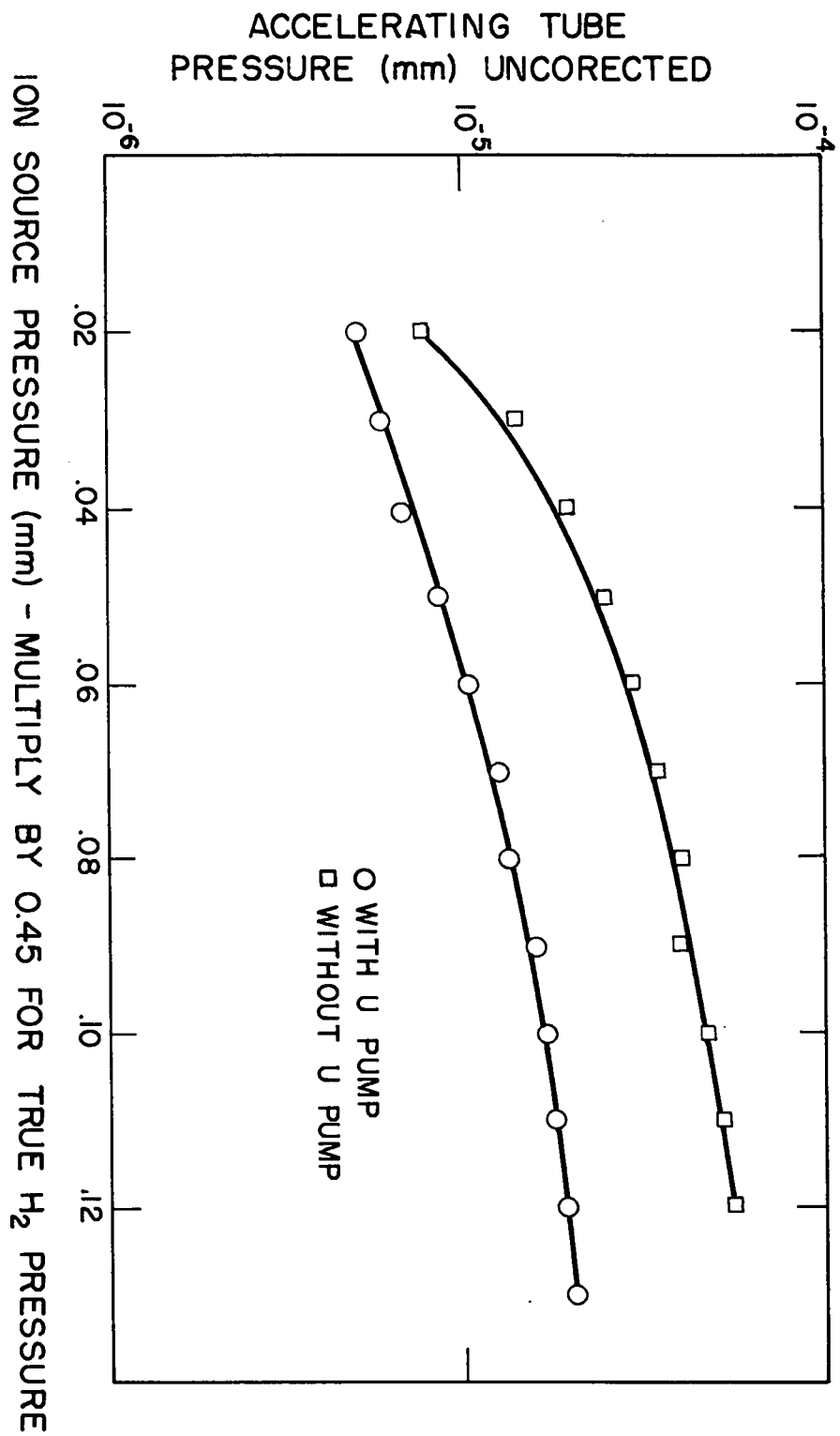

Fig. 3

Same comparison as Fig. 2 for U pump and
for circulating diffusion pump using 1/8"
orifice between the pumping chamber and
the accelerating tube for both cases.

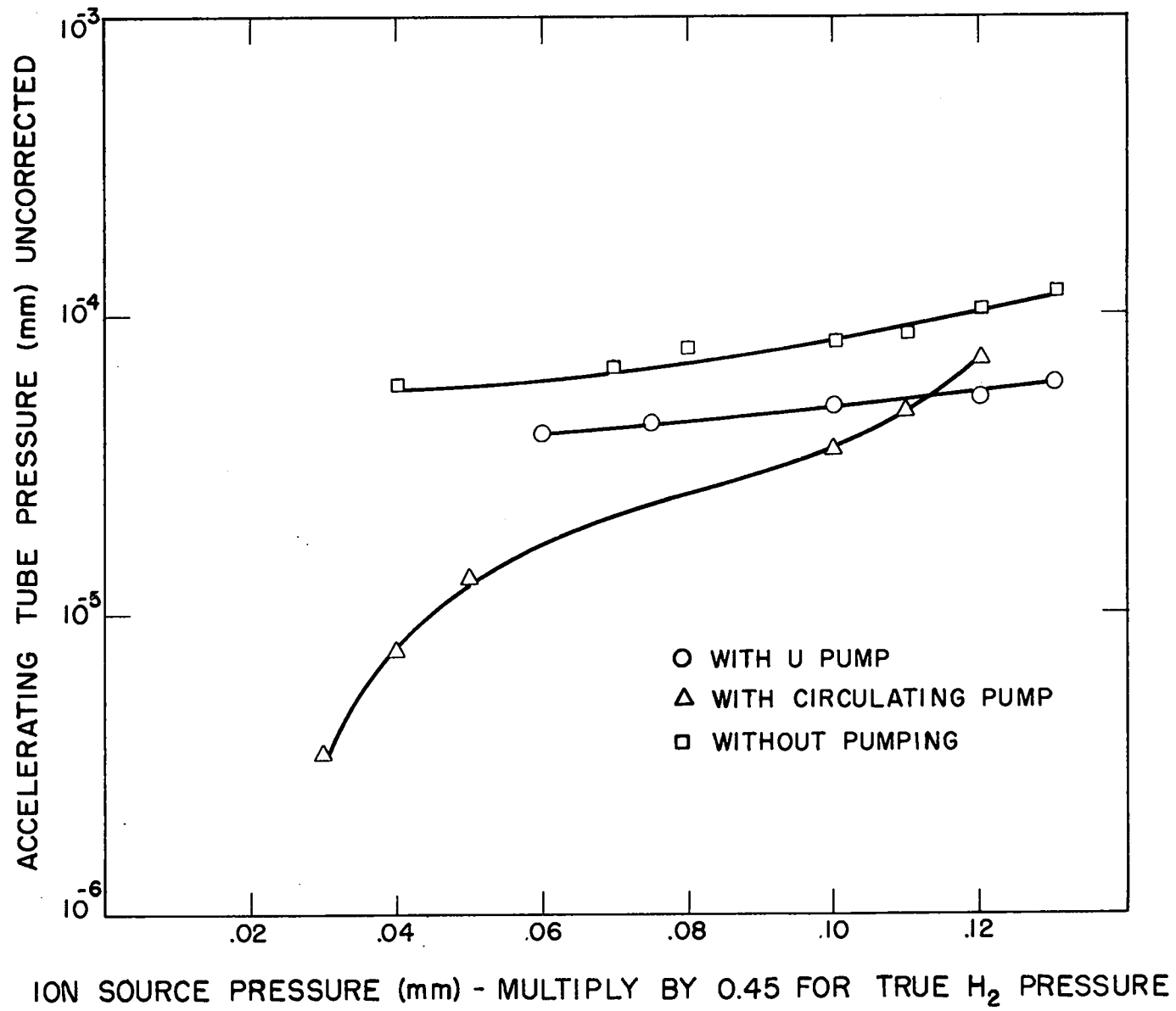
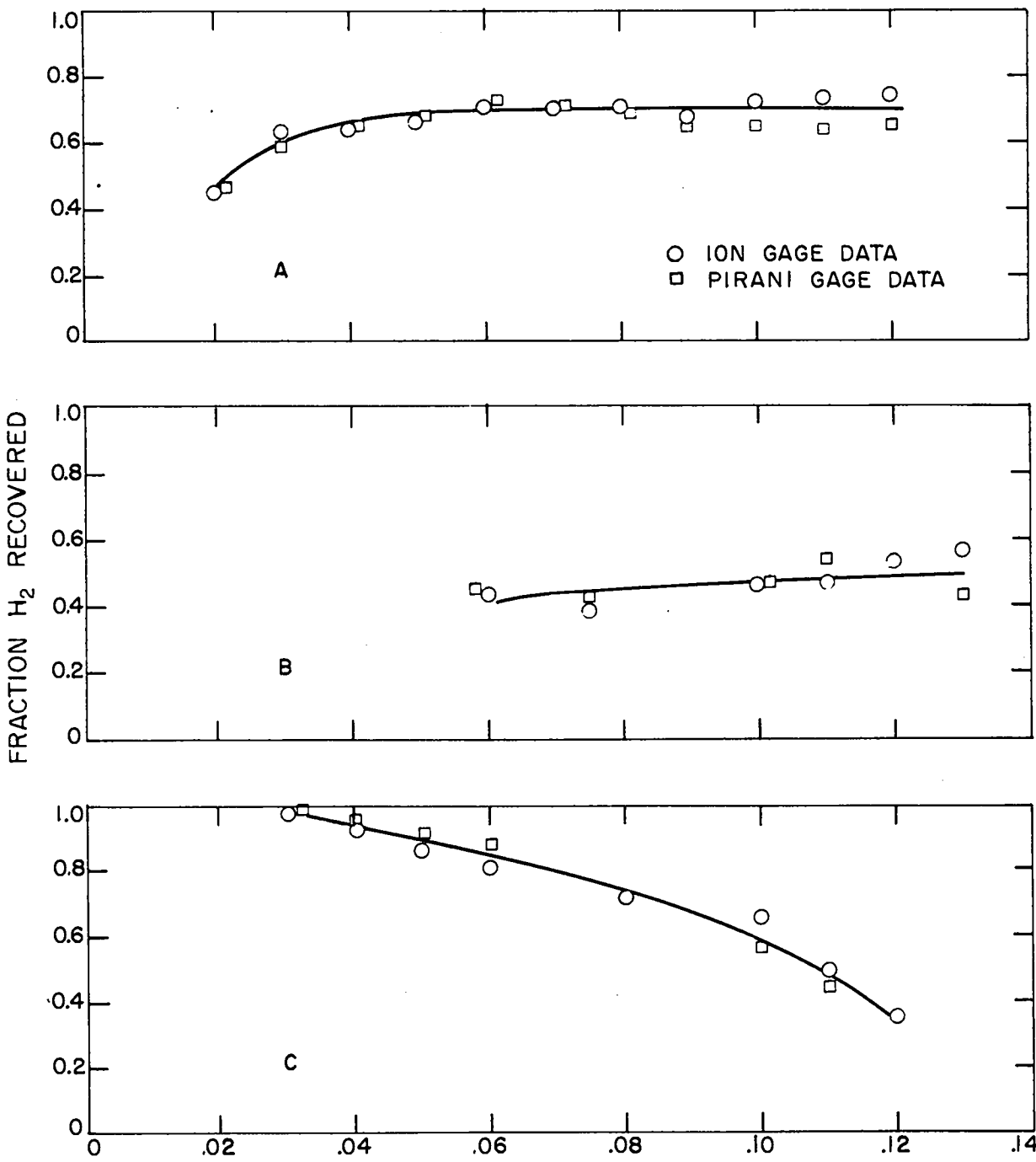

Fig. 4

- (a) 1/16" orifice between pumping chamber and accelerating tube. *U pump next!*
- (b) U pump - 1/8" orifice between pumping chamber and accelerating tube.
- (c) Circulating diffusion pump, 1/8" orifice between pumping chamber and accelerating tube.



ION SOURCE PRESSURE (mm) - MULTIPLY BY 0.45 FOR TRUE H₂ PRESSURE

FIG. 4

*APPENDIX I

The expression given for the fraction of hydrogen recovered was derived by making a material balance for the steady state around the pumping chamber under the two conditions, with and without the absorbing uranium pot. Referring to Fig. 1,

P_1 = accelerating tube pressure near pumping chamber.

P_2 = pumping chamber pressure.

P_3 = ion source pressure.

P_u = dissociation pressure of UH_3 at absorbing pot temperature.

Primed values refer to pressures when the absorbing uranium pot is included in the system.

K_{32} = constant for orifice between pumping chamber and ion chamber.

K_{21} = constant for tube between pumping chamber and accelerating tube.

K_u = constant for flow of hydrogen from the pumping chamber to the uranium pot.

The assumptions made in the derivation of this expression are (1) that the rate of absorption of hydrogen by the uranium pot and the flow of hydrogen down the pumping chamber to the uranium are proportional to the pressure in the pumping chamber; (2) that the flow of gas through the orifices and small tubes of the system is molecular.

*The assistance of W. M. Jones in the development and application of the expressions derived in the Appendixes is gratefully acknowledged.

The derivation is accomplished as follows:

Without the U pot,

$$K_{32} (P_3 - P_2) = K_{21} (P_2 - P_1)$$

but $P_2 \rightarrow P_1$.

$$\text{Therefore } K_{32} (P_3 - P_2) = K_{21} P_2. \quad (1)$$

With the U pot,

$$K_{32} (P_3 - P_2') = K_{21} (P_2 - P_1') + K_u (P_2' - P_u)$$

but $P_2' \rightarrow P_1'$ and $P_2' \rightarrow P_u$.

$$\text{Therefore } K_{32} (P_3 - P_2') = K_{21} P_2' + K_u P_2'$$

$$\text{From relation (1)} \quad \frac{K_{32}}{K_{21}} = \frac{P_2}{P_3 - P_2} \quad (3)$$

Dividing (2) by K_{21}

$$\frac{K_{32}}{K_{21}} (P_3 - P_2') = P_2' + \frac{K_u}{K_{21}} P_2'$$

Using relation (3)

$$\frac{P_2}{P_3 - P_2} (P_3 - P_2') = P_2' + \frac{K_u}{K_{21}} P_2'$$

$$\therefore \frac{K_u}{K_{21}} = \frac{\frac{P_2}{P_3 - P_2} (P_3 - P_2') - P_2'}{P_2'} = \frac{P_2 (P_2 - P_2')}{P_2' (P_3 - P_2)} \quad (4)$$

At any time the fraction λ of H_2 into the uranium is

$$\begin{aligned} \lambda &= \frac{K_u P_2'}{K_u P_2' + K_{21} (P_2 - P_1')} = \frac{K_u P_2'}{K_u P_2' + K_{21} P_2'} = \frac{K_u}{K_u + K_{21}} \\ &= \frac{1}{1 + \frac{K_{21}}{K_u}} \end{aligned} \quad (5)$$

Evidence of you mean that $P_2 \rightarrow P_1$, what is the evidence? No

How can you have both P_2' and P_2 in the same equation? Seems to me that either the U-pot is in the equation or it isn't. No

Substituting (4) for K_{21}/K_u

$$\frac{\lambda}{\mu} = \frac{1}{1 + \frac{P_2^1 (P_3 - P_2)}{P_3 (P_2 - P_2^1)}} = \frac{1}{1 + \frac{P_2^1 / P_2 (1 - P_2 P_3)}{1 - P_2^1 / P_2}} \quad (6), \text{ Eq. (1) of text}$$

APPENDIX II

The comparison of the impedances in the two cases where the 1/16 and the 1/8 inch orifices were used along with a 1/8 inch tube of 1-1/8 inch length was made in the following manner:

R_1 = radius of 1/16 inch orifice = .03125 inches.

R_2 = radius of 1-1/8 inch long tube = .0625 inches.

f_1 = Clausing factor for 1/16 inch orifice (0.572).

L = length of 1/8 inch tube = 1.125 inches.

L = length of orifice = 0.125 inches.

n = fraction of hydrogen recovered by U pump.

Using the Clausing relation⁵ the ratio of the conductances in the two cases is,

$$\frac{K_{21 \ 1/16}}{K_{21 \ 1/8}} = \frac{\frac{1}{R_1^2 f_1} + \frac{1}{R_2^2 \frac{8}{3} \frac{R_2}{L}}}{\frac{R_2^2 \frac{8}{3} \frac{R_2}{L} + \frac{R_2}{L + L}}{L + L}} = 0.55$$

The general expression for n , the fraction of hydrogen recovered, is,

$$(n)_{1/8} = \frac{1}{1 + \frac{K_{21}}{K_u}} ; \quad \frac{K_{21 \ 1/8}}{K_u} = 1$$

$$\therefore \frac{K_{21 \ 1/16}}{(.55) K_u} = 1 ; \quad \frac{K_{21 \ 1/16}}{K_u} = 0.55$$

For the calculated efficiency of the 1/16 inch orifice case

$$(n)_{1/16} = \frac{1}{1 + 0.55} = 0.65$$

A similar calculation can be made for any other size orifice used between the pumping chamber and the accelerating tube.

ADDENDUM: The Use of Uranium as a Pump for Hydrogen

The apparatus used is that of Stephanou's (Fig. 1) with the circulating oil diffusion pump system removed. In addition, the "cold" U pot was moved to within one foot of the pumping chamber with a 1-1/2" low-restriction Kinney valve between. It is estimated that the conductance of the pumping chamber cold pot line was increased by a factor of two over that of Stephanou's set-up.

Besides the references listed by Stephanou, there are two men at Los Alamos who possess the necessary knowledge to increase the efficiency of the method. These men are Eugene S. Robinson and James S. Church. Their data covers the cases of deuterium and tritium also.

The method of determining the fraction recovered is slightly different than that of Stephanou's. It is as follows:

In general, the amount of hydrogen entering the pumping chamber from the ion source is given by $K_{32}(P_3 - P_2)$; where "K" represents the conductance; the amount flowing down the accelerating tube by $K_{21}(P_2 - P_1)$. If the "cold" or pumping pot is closed off from the system, then the two amounts are equal. Hence

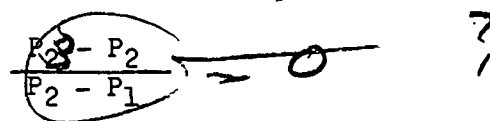
$$\frac{K_{21}}{K_{32}} = \frac{P_3 - P_2}{P_2 - P_1}$$
A hand-drawn diagram showing a horizontal tube with a valve symbol (a circle with a vertical line through it) in the middle. To the right of the tube is a question mark. The diagram is positioned below the equation and above the final paragraph.

and the ratio of the two conductances can be found by noting the pressures in the system when the uranium is not acting as a pump.

However, if the uranium is acting as a pump, the amount of hydrogen absorbed by it equals the amount entering the pumping chamber minus the amount flowing down the accelerating tube. Dividing by the amount entering from the ion source, the fraction of the hydrogen recovered, X , will equal

$$1 - \frac{K_{21} (P_2' - P_1')}{K_{32} (P_3 - P_2)}$$

The pressures were averaged over an extended range in the attached graphs. The pressures were measured with unchecked Pirani gauges using a calibration for hydrogen furnished by the company (Distillation Products).

Runs #1 and #3 were made with the uranium not acting as a pump. Runs #2 and #4 were made with the uranium pumping. For runs #1 and #2 the system was tight, but the protection circuit cut the diffusion pump off causing the pressures to rise suddenly at the higher end. For runs #3 and #4 there was a leak in the system, but the diffusion pump was kept on at the higher pressures. The effect of the leak was to convert some of the powdered uranium to uranium oxide and reduce the efficiency of the pump. In fact for a subsequent run a day later, the uranium was totally converted to oxide.

On the graphs for runs #1 and #3 the points marked with an "X" are points taken with the hot pot cooling off and the pressures decreasing. This was done in order to correct for any lag in the

pressure readings. Run #3 gives the most accurate value for the conductance ratio, mainly because the diffusion pump did not cut off. And it is seen that the effect of lag is negligible.

On all the graphs the circled points are those when the pressure is increasing. During runs #2 and #4 the cold pot absorbed the hydrogen so fast when the hot pot was cooling that it was impossible to take any readings on the way down.

Due to the leak during the last run (#4) it would be expected that the results wouldn't be the optimum for the system. This is also borne out by the greater scattering of the points about the line. Hence it would be expected that the maximum recovery occurred during run #2. Using, then, runs #2 and #3 the percentage recovered turns out to be 88%. Using runs #1 and #4 it is 75%. The figure 88% is probably the maximum for the apparatus used.

There are at least two ways that this figure could be increased. One is by running the cold pot at a higher temperature so that the rate of reaction is speeded up, while still not increasing the dissociation pressure appreciably since the pressure at the uranium was only a few micron less than the pressure in the pumping chamber (Pirani gauge). The other is dispersing the powder in such a fashion that more surface area is available. A third possible way is to move the pot closer to the pumping chamber. But because of the necessity of a large, low-constriction valve in the line, it is thought that the distance of about one foot in the present apparatus is the closest

that it can be placed.

The disadvantages to this set-up are several. If suddenly a large leak appears in the system, the UH_3 will oxidize violently causing a serious fire hazard. The presence of even a small leak will slowly cause the uranium powder to be converted to uranium oxide, losing all ability to absorb hydrogen. And the apparatus used by Stephanou was found to have a thin deposit of uranium oxide powder all through it.

An obvious advantage, other than the conservation of gas, is the factor of eight by which the accelerating tube pressure is reduced under optimum operation. *Where is this shown?*

In conclusion then, the method obviously works, but the disadvantages listed would probably prevent it from being used if any other method were available.

The sections marked on pages 5 and 7 and a good bit of the Addendum read to me like apologies for not having done a good job. This report has been sent to 71 different places. Seems to me we should have kept it at home
25 May '52 *EJY*

