

LA-9154-MS

C. 1

Los Alamos National Laboratory is operated by the University of California for the United States Department of Energy under contract W-7405-ENG-36.

For Reference

Not to be taken from this room

*Final Processing of
Impure Plutonium Dioxide to
High-Purity Plutonium Metal*

LOS ALAMOS NATIONAL LABORATORY



3 9338 00307 4290

Los Alamos Los Alamos National Laboratory
Los Alamos, New Mexico 87545

Presented at the Symposium on Actinide Recovery from Waste and Low Grade Sources, Annual Meeting of American Chemical Society, New York City, August 23-28, 1981.

DISCLAIMER

This report was prepared as an account of work sponsored by an agency of the United States Government. Neither the United States Government nor any agency thereof, nor any of their employees, makes any warranty, express or implied, or assumes any legal liability or responsibility for the accuracy, completeness, or usefulness of any information, apparatus, product, or process disclosed, or represents that its use would not infringe privately owned rights. References herein to any specific commercial product, process, or service by trade name, trademark, manufacturer, or otherwise, does not necessarily constitute or imply its endorsement, recommendation, or favoring by the United States Government or any agency thereof. The views and opinions of authors expressed herein do not necessarily state or reflect those of the United States Government or any agency thereof.

Fused Salt Processing of Impure Plutonium Dioxide to High-Purity Plutonium Metal

L. J. Mullins
D. C. Christensen
B. R. Babcock



CONTENTS

	PAGE
ABSTRACT	1
I. INTRODUCTION	1
II. SCHEMATIC FLOWSHEET FOR THE CONVERSION OF PLUTONIA SCRAP TO . . . HIGH-PURITY METAL.	2
III. DIRECT OXIDE REDUCTION PROCESS	3
A. Basic Principles	3
B. Oxide Feed Specifications.	3
1. Physical Properties	3
2. Isotopic Composition	4
3. Chemical Purity	4
C. Equipment and Materials	5
D. Operating Procedure	6
E. Discussion	9
F. Results.	10
IV. ELECTROREFINING PROCESS.	11
A. Basic Principles	11
B. Metal Feed Specifications	12
1. Physical Properties.	12
2. Chemical Purity.	12
C. Equipment and Materials	12
D. Operating Procedure	14
E. Discussion and Results	16
V. CONVERSION OF IMPURE PLUTONIA TO HIGH-PURITY METAL	18
VI. FUTURE WORK	21
REFERENCES	21

FUSED SALT PROCESSING OF IMPURE PLUTONIUM DIOXIDE TO HIGH-PURITY PLUTONIUM METAL

by

L. J. Mullins, D. C. Christensen, and
B. R. Babcock

ABSTRACT

We have developed a process for converting impure plutonium dioxide (~96% pure) to high-purity plutonium metal (>99.9%). The process consists of reducing the oxide to an impure plutonium metal intermediate with calcium metal in molten calcium chloride. The impure intermediate metal is cast into an anode and electrorefined to produce high-purity plutonium metal.

The oxide reduction step is being done now on a 0.6-kg scale with the resulting yield being >99.5%. The electrorefining is being done on a 4.0-kg scale with the resulting yield being 80-85%. The purity of the product, which averages 99.98%, is essentially insensitive to the purity of the feed metal. The yield, however, is directly dependent on the chemical composition of the feed.

To date, approximately 250 kg of impure oxide has been converted to pure metal by this processing sequence. The availability of impure plutonium dioxide, together with the need for pure plutonium metal, makes this sequence a valuable plutonium processing tool.

I. INTRODUCTION

The use of electrorefining (ER) for the routine processing of impure plutonium metals and alloys to high-purity metal has been an established procedure at Los Alamos since 1964. During the period 1964-1977, 1930 kg of metal fabrication scrap of <99% purity was converted to 1568 kg of high-purity plutonium metal, >99.95% purity, in 653 runs.¹

The use of direct oxide reduction (DOR) procedures for the routine processing of plutonium dioxide to metal is a fairly recent innovation. Processes for the conversion of 200-g batches of $^{238}\text{PuO}_2$ and $^{239}\text{PuO}_2$ to metal were developed in 1975-1976.² The process was later extended to the 400- and 700-g scale for $^{239}\text{PuO}_2$ operations.³

For the past 3 years, we used the combination of DOR/ER for the routine recycle of impure $^{239}\text{PuO}_2$ to high purity metal. The recent shortage of plutonium metal,⁴ the availability of plutonium oxide scrap, and the cost effectiveness of the process have resulted in increased interest in this processing route.

II. SCHEMATIC FLOWSHEET FOR THE CONVERSION OF PLUTONIA SCRAP TO HIGH-PURITY METAL

The process schematic for the conversion of plutonia scrap to pure metal is given in Fig. 1. This flowsheet is considered in more detail in Sec. V. Plutonia scrap is reduced to impure metal that is electrorefined to produce high-purity metal.

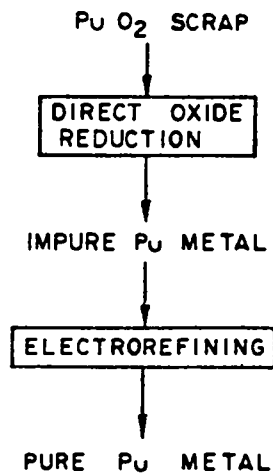

Fig. 1. Conversion of plutonia scrap to pure metal.

III. DIRECT OXIDE REDUCTION PROCESS

A. Basic Principles

A review of processes for reducing plutonium compounds to metal is given in Ref. 2. Most plutonium facilities react either PuF_4 or a mixture of (75 mol% PuF_4 - 25 mol% PuO_2) with calcium. An initiator of $(\text{Ca} + \text{I}_2)$ or a pyrotechnic initiator is used in the PuF_4 reductions.

There are many advantages to reducing PuO_2 directly to metal. They include

(a) Ease of preparation of PuO_2 . Plutonium metal and all of its compounds, except the phosphate, are converted to PuO_2 when they are heated in air.

(b) Availability of PuO_2 . Plutonium dioxide constitutes the bulk of scrap materials in storage. The usual form is foundry oxide, which is quite unreactive and cannot be converted to PuF_4 by conventional hydrofluorination procedures. This oxide, however, can be reduced by DOR.

(c) Decrease in personnel neutron exposures. Personnel neutron exposures are reduced by eliminating the use of PuF_4 (that is, PuF_4 is a high neutron emitter because of the (α, η) reaction, $^{19}\text{F}(\alpha, \eta)^{22}\text{Na}$).

The reduction of PuO_2 by Ca metal is done in a CaCl_2 solvent. The reaction is

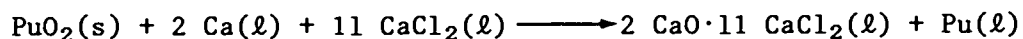

Thus, the CaCl_2 dissolves the CaO by-product permitting coalescence of plutonium metal in a massive pool.

B. Oxide Feed Specifications

1. Physical Properties. We have no physical property limitations on the oxide feed. High-fired, unreactive oxides, as well as the more reactive oxides prepared by the calcination of oxalates and peroxides, can be reduced to metal with high yields.² Most of the oxides we process are either foundry oxides, resulting from the burning of plutonium casting skulls, or impure oxide resulting from the calcination of $\text{Pu}_2(\text{C}_2\text{O}_4)_3 \cdot x\text{H}_2\text{O}$. This latter oxide is usually the product from the recovery of plutonium wastes by aqueous methods.

2. Isotopic Composition. We have no plutonium isotopic limitations on oxide feed. We have routinely processed feeds containing as much as 20-21% ^{240}Pu with no variation in procedures and no decrease in yields.

3. Chemical Purity. Present chemical purity specifications for oxide feed are given in Table I. These specifications serve as a guide for nuclear

TABLE I
CHEMICAL PURIFICATION DATA FOR ELECTROREFINING
AND CHEMICAL SPECIFICATIONS FOR OXIDE FEED

Element	Electrorefining Data, Concentration, ppm ^a of Element In		Oxide Feed Specification (wt%)
	Feed	Product	
Li	<1	<0.005	N.L. ^b
Be	250	10	0.01 Max ^c
B	<10	<0.05	N.L.
Na	110	<10	0.25 Max
Mg	300	1	0.25 Max
Al	2000	<1	0.20 Max ^c
Si	320	<5	0.10 Max ^c
K	45	<10	N.L.
Ca	500	<10	N.L.
Sc	-	-	0.10 Max ^c
Ti	15000	10	1.5 Max
V	-	-	0.10 Max
Cr	340	<5	N.L.
Mn	200	<0.1	0.10 Max ^c
Fe	25800	20	2.5 Max
Co	23000	<0.5	2.3 Max
Ni	>1000	<0.5	0.50 Max ^c
Cu	500	<1	0.50 Max ^c
Zn	1000	<5	0.50 Max ^c
Ga	12900	<20	1.0 Max
Rb	-	-	N.L.
Sr	-	-	N.L.
Y	8000	<0.4	0.80 Max ^c
Zr	1000	14	0.40 Max
Mo	1000	<0.5	N.L.
Cd	<3	<0.5	0.50 Max ^c
Sn	1000	<1	0.10 Max ^c
Cs	-	-	N.L.
Ba	-	-	N.L.
La	<10	<1	N.L.
Hf	2000	<0.5	N.L.
Ta	5000	80	0.10 Max ^c
W	65	<2.5	0.10 Max ^c
Re	-	-	N.L.
Pb	1000	<0.5	0.10 Max ^c
Bi	50	>1	0.10 Max ^c
Th	1300	10	1.0 Max
U	656	20	0.1 Max ^c
Am	1000	130	N.L. ^d
C	1800	15	N.L. ^d
Tm	1350	>10	0.20 Max ^c
Ir	4500	110	0.50 Max ^c

^a g of Element/10⁶ g of sample.

^b No limit.

^c Values might be raised if these limits present a problem.

^d Carbon is removed in the oxide roasting step. The carbon content of an electrorefining feed, however should not exceed 0.36%.

material managers in selecting processing routes. Oxides that meet these specifications are processed by DOR/ER. In most cases, product metal purity requirements and electrorefining limitations set the specifications. As shown in Table I, some of the specifications are based on experimental data. In other cases, (zirconium and thorium), phase diagrams were used to calculate the concentration of the elemental impurities that would permit 90% depletion of the plutonium anode before solidification occurs at 750°C. Table I serves only as a guide. The limitations on purity are probably conservative and might be changed if operational data show they are too restrictive.

The specification for plutonium concentration is that the plutonium value should be equal to or greater than 85%. This corresponds to an oxide purity of 96.4% for the usual isotopic mix. Again, this number is a guide for screening oxide feeds. More definitive work could result in a relaxation of this criterion.

C. Equipment and Materials

The oxide reduction equipment is shown in Fig. 2. The reduction is done in a magnesia crucible contained in a tantalum safety can and a stainless steel loading can. The loading can is contained in a sealed furnace tube having an argon atmosphere and is heated by a resistance furnace, Lindberg Model 6015S. The reaction mixture is stirred by a tantalum stirrer fitted with two sets of oppositely pitched impellers. As the stirrer is rotated clockwise, the bottom impeller lifts the plutonia into the molten salt and the top impeller pulls the calcium metal down into the molten salt. Temperature is measured by a Chromel-Alumel thermocouple immersed in the melt and protected by a tantalum-nickel sheath. The outer tube is tantalum and the inner tube is nickel. The tantalum is resistant to the components of the reaction mixture and the nickel protects the tantalum from air oxidation and provides mechanical strength. The upper ends of the tantalum and nickel tubes are welded together.

The magnesia crucibles are highly vitrified bodies and are fabricated commercially.

The calcium chloride is Mallinckrodt's 4104 Anhydrous Calcium Chloride. Before using, we dry it under vacuum at 225°C for approximately 5 days and then isostatically press it into cylinders.

The calcium metal is Pfizer's Redistilled-Grade, 6-mesh nodules.

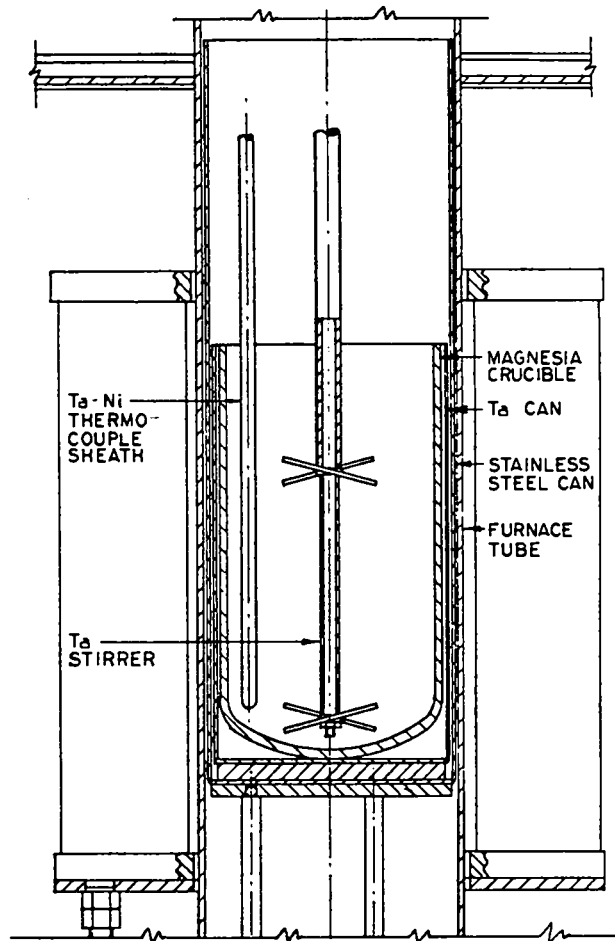

Fig. 2. Plutonia reduction equipment.

D. Operating Procedure

Approximately 700 g of roasted plutonia (see Sec. V for roasting conditions) are poured into a magnesia crucible (Los Alamos body A-480). With the crucible in the vertical position, the PuO_2 is covered with a 100-g layer of anhydrous calcium chloride powder. The 301 g of calcium metal is then placed on this powder. Finally, a 3.5-kg cylinder of CaCl_2 is placed on the calcium. The crucible is loaded into the tantalum safety can, which is placed in the stainless loading can. This assembly is then placed in the furnace tube and the cover plate is bolted in place. A vacuum is pulled on the furnace tube, which is checked for gas tightness. The furnace tube is then filled with argon gas to 4 psig.

The crucible is heated at a maximum rate of $200^\circ\text{C}/\text{h}$ to the melting point of CaCl_2 , 772°C . The thermocouple sheath and stirrer are then lowered into the melt

to the position shown in Fig. 2. When the temperature reaches 800°C, stirring is initiated at 200 rpm. An immediate increase in temperature occurs. After 1 to 2 min at 200 rpm, a leveling of the temperature takes place, the stirring is then increased slowly to 400 rpm, and then increased to 600 rpm. The temperature profile for a typical run is given in Fig. 3. The reaction usually is complete in less than 5 minutes; however, stirring is continued for a total time of 15 minutes. If the temperature of the melt reaches 839°C (the melting point of calcium metal) before a 600-rpm stirring rate is achieved, the rate is immediately increased to 600 rpm. This is done to minimize the reaction

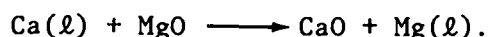

This practice ensures thorough stirring and minimal contact of calcium with the magnesia crucible. Usually, the maximum temperature reached is 875°C. A drop in temperature indicates completion of the reduction. Upon completion of the 15-minute stirring period, the stirrer speed is slowly decreased to zero rpm. By this time, the temperature levels out at ~850°C. (Note. The temperature must be kept above 835° to achieve a high solubility of CaO in CaCl₂.⁵) To promote good metal collection, the stirrer is raised 2 inches, reactivated, and the speed slowly increased to 200 rpm. After 2 minutes at 200 rpm, the speed is slowly reduced to 0 rpm and the stirrer is allowed to drain for 5 minutes. The stirrer and thermocouple sheath are then raised from the melt and the furnace is shut off.

The furnace is allowed to cool for at least 4 hours before unloading. The stainless loading can is removed from the furnace and inverted to remove its

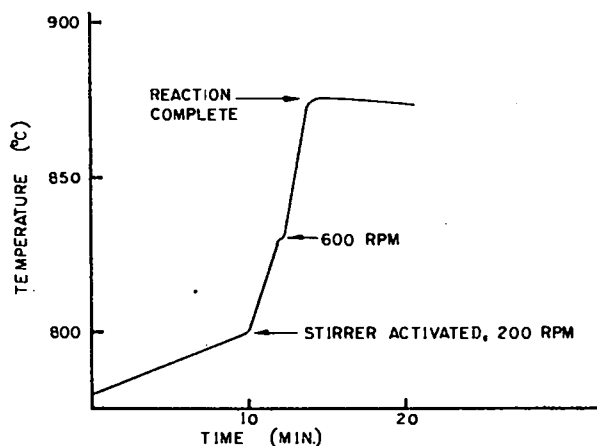

Fig. 3. Temperature vs time, typical reduction.

contents. The metal button is removed from the magnesia crucible by breaking away the bottom of the crucible. As shown in Fig. 4, the button separates cleanly from the salts and crucible and can easily be removed by breaking away the bottom of the crucible. The residues consisting of the CaCl_2 - CaO salt and magnesia crucible are assayed for plutonium by neutron coincidence counting.

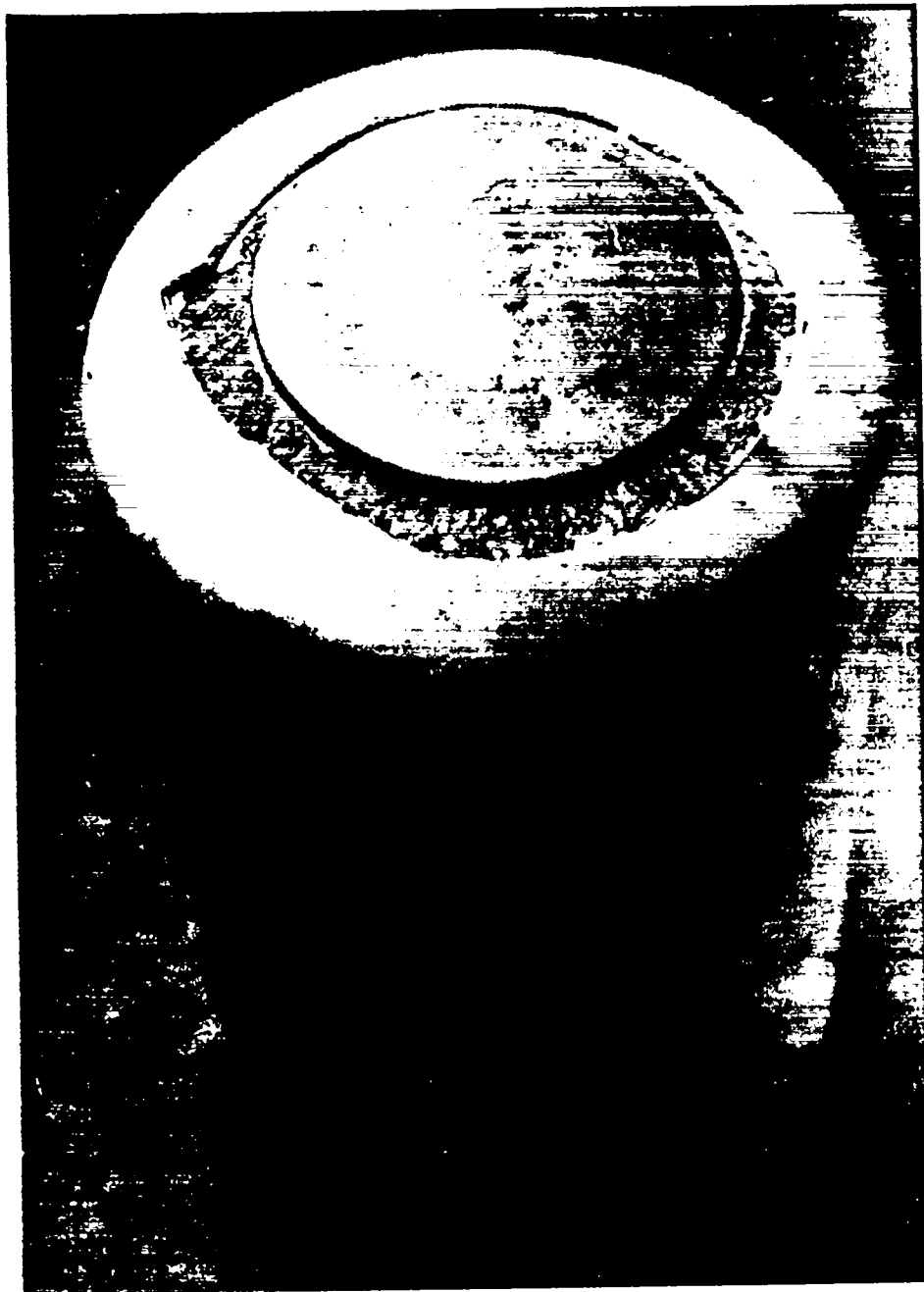

Fig. 4. DOR product and residues.

E. Discussion

The success of DOR is dependent on many parameters.² The four most important are

(a) Stirring. Effective stirring of the reaction mixture is absolutely essential. High density PuO_2 (11.46 g/cm^3) must be lifted off the bottom of the crucible and dispersed into molten CaCl_2 . Low-density calcium metal (1.54 g/cm^3) must be stirred into the CaCl_2 so it can react with PuO_2 . (In addition, dispersion of calcium metal into the melt minimizes attack of liquid calcium metal on the MgO crucible.) The reaction by-product, CaO , must be dissolved in the CaCl_2 as it is formed to permit good collection of the plutonium metal product and good phase separation of plutonium metal from the $\text{CaCl}_2 - \text{CaO}$ melt. Poor stirring will result in incomplete reduction of PuO_2 , poor metal collection, and poor metal-salt phase separation.

(b) Solvent capacity. The phase diagram for the $\text{CaCl}_2 - \text{CaO}$ system⁵ shows that the solubility of CaO in CaCl_2 is 18.5 mol% at 835°C . This solubility sets the maximum ratio of g Pu/g CaCl_2 at a value of 0.245. Attempts to achieve this value² were unsuccessful and a value of 0.17 g Pu/g CaCl_2 was established for practical operating conditions. It should be realized that virtually all of the oxide impurities present in the oxide feed also react with calcium metal resulting in the formation of CaO , namely,



If the impurities are primarily light element oxides, enough CaO can be produced to interfere with the plutonia reduction. This can result in incomplete reduction of PuO_2 and poor plutonium metal collection. Fortunately, these poor runs are easily identified and the plutonium materials can be recycled into another run. This is accomplished by cleaving the bottom of the salt residue away from the main body of the $\text{CaCl}_2 - \text{CaO}$ and loading this salt bottom and plutonium metal into a new run. The top portion of the salt usually contains <1 g plutonium.

(c) Temperature measurement. Direct measurement of the salt temperature is essential in the DOR process. Stirrer initiation and stirring rates are controlled by temperature measurement (see Sec. III.D). Control of the melt temperature is important in achieving maximum solubility of CaO in CaCl_2 and in minimizing

the attack of MgO by liquid calcium. Progress of the reduction is easily followed by observing the melt's temperature trace, which clearly shows initiation and completion of the reaction (see Fig. 3).

(d) Dry reagents. The importance of using anhydrous CaCl_2 and PuO_2 cannot be overemphasized. Extreme care must be exercised in handling CaCl_2 because it is so hygroscopic. Calcium chloride can be dried easily in vacuum-drying ovens without any appreciable hydrolysis. The dried powder, however, must be handled in dry atmospheres to avoid water pickup. Once the CaCl_2 cylinders are pressed, water pickup is less of a problem. However, all cylinders are stored in vacuum drying ovens at 225°C after pressing. If moisture remains in the reagents, many problems arise. Foaming during the heat up and melting is most common. This results in a loss of CaCl_2 as a solvent for CaO. In addition, at the high reaction temperature, water reacts with both CaCl_2 and calcium to form CaO. This further reduces the solvent capacity of the CaCl_2 for the intended CaO reaction by-product. Regardless of mechanism, the result is a poor reduction yield. These runs generally must be rerun with a fresh CaCl_2 salt cake.

F. Results

The results of a typical plutonia reduction are given in Table II. Typically, 700 g of oxide feed containing 595 g of plutonium is reduced to metal with a yield of 99.5%. The plutonium held up on the tantalum stirrer is recycled to the next run. Essentially no purification is achieved in DOR. The product contains all of the impurities present in the oxide feed plus those introduced by DOR reagents, namely, calcium, boron, and carbon (see Sec. V).

More than 250 kg of impure oxide have been converted to impure metal by DOR.

TABLE II

RESULTS OF TYPICAL PLUTONIA
REDUCTIONS (700 g Scale)

<u>Feed Materials</u>	<u>g Pu</u>
700 g Oxide	595
21 g Metal on Stirrer	20
301 g Ca metal	
3.6 kg CaCl ₂	
<u>Reaction Products</u>	
614 g Metal Button	592
21 g Metal on Stirrer	20
<u>Residues (salt and crucibles)</u>	3
<u>Reduction Yield</u>	99.5%

IV. ELECTROREFINING PROCESS

A. Basic Principles

Plutonium electrorefining principles are summarized in Ref. 1. Briefly, the process consists of oxidizing plutonium from an impure metal feed at the anode and reducing it to pure metal at the cathode, that is,

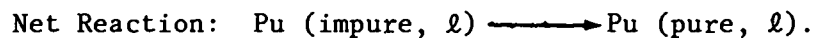
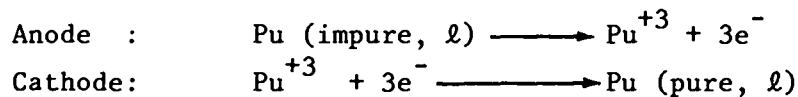

The process is done at 740°C in a molten salt consisting of NaCl-KCl-PuF₃, under near-equilibrium conditions. Virtually all of the impurities concentrate in the anode. Of the impurities usually present in plutonium, only americium concentrates in the salt.

B. Metal Feed Specifications

1. Physical Properties. The feed to ER must be metal. It can be impure plutonium metal or alloys of plutonium. The metal is vacuum-cast into a cylinder prior to electrorefining. The primary purpose of the casting is to put the metal into the proper geometry for loading 4 kg of plutonium into the anode cup. The vacuum-casting also removes volatile metallic impurities such as calcium and magnesium and concentrates impurities such as PuO_2 in the casting residue. The presence of small amounts of PuO_2 will not negate the electrorefining; however, excessive amounts should be avoided. For this reason, oxidized anode cylinders are thoroughly brushed before loading.

2. Chemical Purity. Because no purification takes place in DOR, the purity of the ER feed is dependent on the DOR feed. In practice, the ER feed is inferior because all of the reagent impurities of the DOR process are scavenged by the active plutonium metal product of DOR.

One of the design goals of ER is to deplete at least 90% of the plutonium anode before solidification or phase separation of the anode terminates the electrorefining. (For a thorough discussion of this point, see Ref. 1.) As stated in Sec. III. B.3 and seen in Table I, most of the oxide chemical specifications are based on ER empirical results. In some cases (zirconium, thorium, and carbon) phase diagrams were used to calculate the initial impurity concentration in the feed metal that would permit 90% anode depletion. Thus the data in Table I serve as a guide only and any change in operating conditions can affect the extent of anode depletion. In addition, the values in Table I can be changed when empirical results indicate that it is appropriate.

C. Equipment and Materials

The electrorefining equipment is shown in Fig. 5. The process is performed in a double-cupped magnesia crucible. As in DOR, the crucible is contained in a tantalum safety can and a stainless steel loading can. The loading can is contained in an identically sealed furnace tube and heated by an identical resistance furnace (Lindberg Model 6015S) as in the DOR process (see Fig. 2).

A schematic of the electrorefining cell is given in Fig. 6. The electrorefining crucible consists of two magnesia crucibles cemented together. The inner cup contains the impure metal feed. Both the impure metal and the molten salt electrolyte are stirred by a magnesia stirrer. A tungsten rod suspended in the

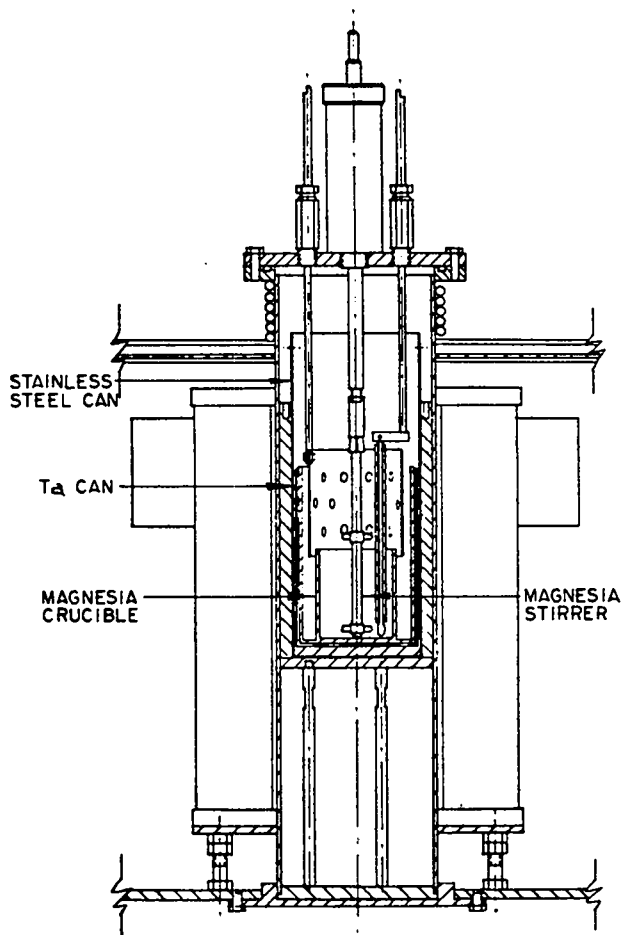

Fig. 5. Electrorefining process equipment.

impure metal pool serves as the anode rod. The anode rod is electrically insulated with a magnesia sleeve. A cylindrically shaped sheet of tungsten is suspended in the annular space between the two cups and serves as the cathode. The magnesia crucible and the magnesia stirrer are highly vitrified bodies and are fabricated commercially.

Raw materials for the anode rod and cathode are purchased commercially and the actual parts are fabricated at Los Alamos.

The sodium chloride and potassium chloride reagents are AR grade and are purchased commercially. The salts are dried overnight under vacuum at $\sim 150^{\circ}\text{C}$ and then cast into cylinders. Before use, a hole is drilled in one end of the salt casting.

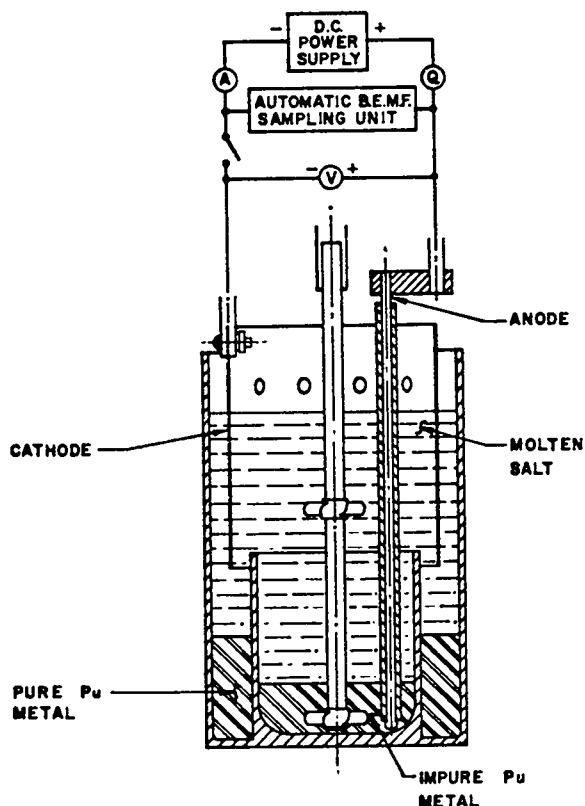

Fig. 6. Schematic of electrorefining cell.

D. Operating Procedure

The plutonium feed to the process is approximately a 4-kg cylindrical ingot. The ingot is placed in the inner cup of the crucible. The crucible is loaded into the tantalum safety can, which is then placed in the stainless loading can. The assembly is then lowered into the furnace tube. The 1400-g salt casting is placed, hole up, on top of the inner crucible cup. The PuF_4 reagent is poured into the hole of the salt casting. The cover, containing the stirrer, cathode, and anode rod is then bolted to the furnace tube. A vacuum is pulled on the furnace tube and the assembly is checked for gas tightness. The furnace tube is then filled with argon gas to 4 psig. The crucible is heated at a rate of $50^\circ\text{C}/\text{h}$ to 750°C .

The stirrer, cathode, and anode rods are lowered into position. The actual electrorefining process is accomplished by stirring at 800 rpm and passing a dc current between anode and cathode. The electrorefining is preceded by a pre-equilibration and pre-electrolysis treatment that purifies the electrolyte (see Ref. 1). As plutonium is dissolved at the anode, the level of metal in the inner cup drops. Plutonium ions are reduced to metal on the cylindrical tungsten cathode. The plutonium drips off the bottom of this cylinder in large globules and collects in the annulus between the small and large crucibles. The progress of a run is monitored automatically by the back EMF Sampling Unit.⁶ This simple device operates by interrupting the dc current periodically and measuring the polarization potential of the chemical cell

$\text{Pu (pure)}/\text{NaCl-KCl-PuF}_3$ (impure).

If the polarization potential exceeds a preset value, the dc current stays off. Thus, the electrorefining is terminated automatically. This measuring device permits unattended operation of the electrorefining process and terminates a run before impurities are dissolved. Upon completion of the electrorefining, the stirrer, anode rod, and cathode cylinder are raised from the melt and heating is discontinued. After cooling and unloading, the metal ring product is isolated from the crucible and salt. (A typical ring is shown in Fig. 7.) The anode residue and the salt-crucible residues are processed by aqueous methods.⁷

Typical conditions for a 4-kg scale electrorefining are given in Table III. The anode feed weighs 4100 g and contains 4000 g plutonium. The amount of PuF_4

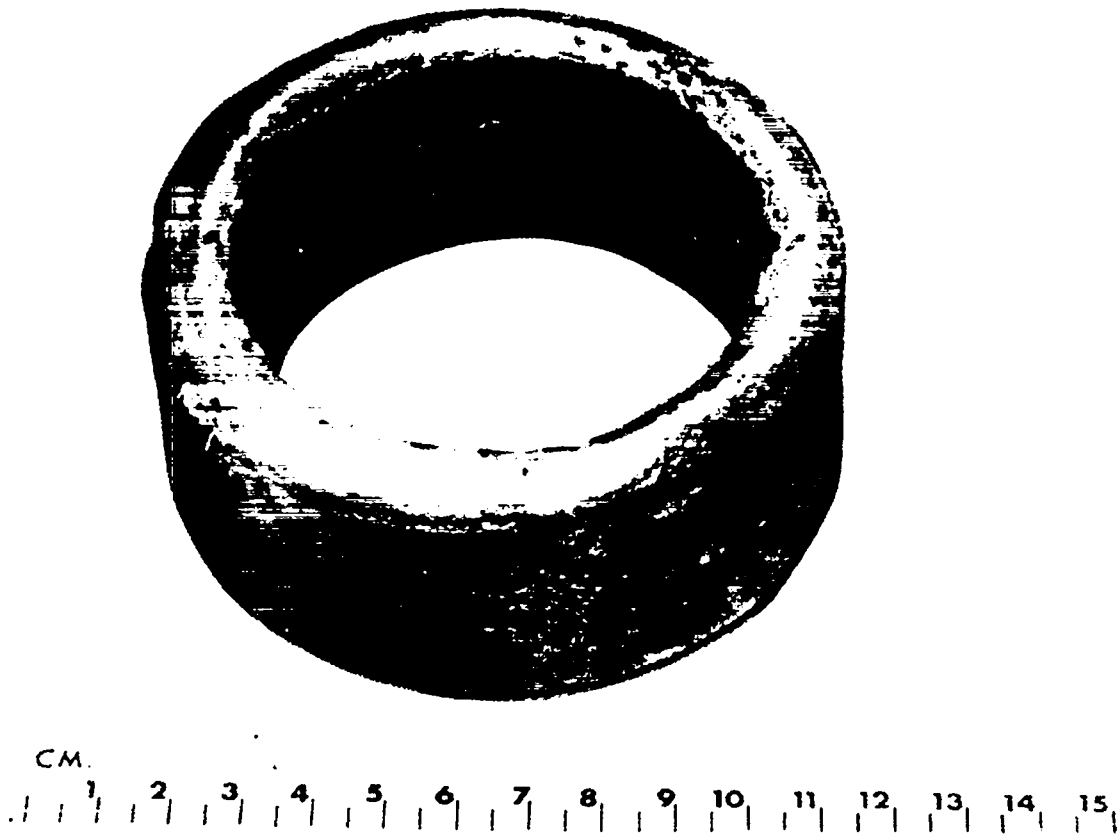

Fig. 7. Typical electrorefining product ring.

TABLE III

TYPICAL CONDITIONS FOR ELECTROREFINING
(4-kg Scale)

Weight of impure Pu, g	4100
Weight of NaCl-KCl, g	1400
Weight of PuF ₄ , g	120
Temperature, °C	750
Current, A	20
Pu Collection rate, g/h	59

added is determined by the requirements for americium removal. (For a detailed discussion of this point, see Ref. 1.) The maximum direct current used is 30 A. The actual current used for any particular run is calculated to permit termination of the run at a convenient time (Note. The units are manned on a 40-hour week.) For most runs, the current is approximately 20 A.

E. Discussion and Results

A typical material balance for a 4-kg electrorefining run using an impure Pu-1 wt% Ga alloy feed is given in Table IV. The product yield is 82.5% ($100 \times 3300/4000$). The fraction of anode depletion is 0.90 $[(4000-400)/4000]$. The metal collection yield is 91.7% $[100 \times 3300/(4000-400)]$.

As discussed in Ref. 1, product yields are a function of anode depletion and metal collection (that is, Product Yield = $0.90 \times 91.7\% = 82.5\%$). For the case of a Pu-1 wt% Ga anode, the maximum depletion that can be expected is 0.90.⁶ This results from the fact that the alloy becomes solid when 90% of the plutonium has been dissolved anodically. One can expect much larger depletion values for impure alpha phase anodes that contain a liquid phase at high depletion values.¹ Collection yields, on the other hand, are a function of several variables¹ and usually range from 90 to 95%. The plutonium product, which is now

TABLE IV
TYPICAL PLUTONIUM MATERIAL BALANCE, ELECTROREFINING,
IMPURE Pu-1 WITHOUT Ga FEED

<u>Plutonium Into Run, g Pu</u>	
Metal Feed,	4000
PuF ₄ ,	91
Cathode,	<u>40</u>
Total	4131
<u>Plutonium Out Of Run, g Pu</u>	
Pure Pu Product	
Ring	3300
Cathode	40
Residues	
Anode	400
Salt & Crucible	<u>391</u>
Total	4131

collected, exists in several forms. Most of it remains in the product collection zone as unconsolidated plutonium shot. Some metal reacts with the crucible wall to which it adheres. A smaller amount is unreduced Pu⁺³.

Purification results from a quite impure metal feed are given in Table V. (Typical results are given in Sec. V.) This table emphasizes the tremendous purification capabilities of the electrorefining process. Product purity is essentially insensitive to the purity of the feed metal. The only real requirement for the feed is that it be molten or contain a single liquid and solid phase at the temperature of the electrorefining. For discussion of this point, see Refs. 1 and 6.

TABLE V
PURIFICATION OF PLUTONIUM METAL, RESULTS WITH AN IMPURE FEED

Element	g Element/10 ⁶ g Pu	
	Feed	Product
Mg	100	2
Al	200	1
Si	50	5
Ca	100	<3
Cr	1000	<0.5
Mn	100	<0.1
Fe	5000	5
Ni	200	2
Cu	100	1
Zn	1000	<0.5
Mo	1000	<0.5
Cd	2000	<0.5
Sn	2000	<0.5
Pb	2000	<0.5
W	<10	60
Th	140	4
U	80	14
Am	140	20
Ga	1.04 x 10 ⁴	<25
Pu, wt%	97.0	99.98

V. CONVERSION OF IMPURE PLUTONIA TO HIGH-PURITY METAL

The flowsheet for the conversion of impure plutonia to high-purity metal is given in Fig. 8. Small cans of PuO_2 , typically 900 g, are combined to make a

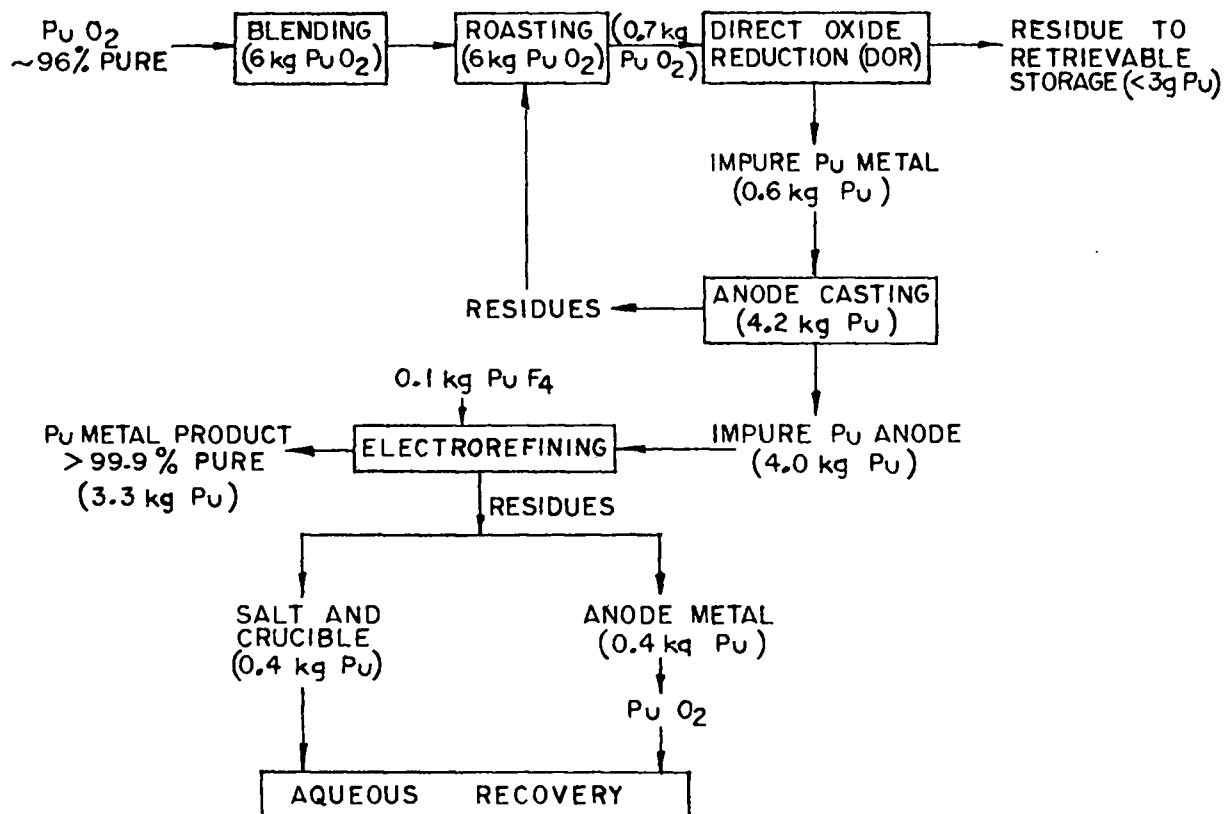

Fig. 8. Conversion of impure plutonia to high-purity metal.

6-kg lot. The 6-kg lot is then heated in air at 800°C for 5 hours to ensure the absence of water, sulfate, and adsorbed gases. Seven hundred gram batches of oxide are aliquoted for oxide reduction. Each reduction yields approximately 600 g of impure metal. Approximately seven metal buttons are combined and cast under vacuum into a 4-kg cylinder that serves as feed to the electrorefining process. Residues from the casting step, about 5% of the casting feed, are recycled to the roasting operation. The electrorefining yields a product ring and two types of residues, an anode containing virtually all of the impurity elements and a crucible-salt residue containing plutonium and americium. The residues are recycled through aqueous recovery. Approximately 3.3 kg of pure metal product are produced per run. Because anode casting residues are recycled to the roasting

operation, the only losses in the process are the residues from DOR and ER. The overall product yield is therefore 82% ($82.5\% \times 0.995$). A plutonium material balance for the combined flowsheet is given in Table VI.

TABLE VI

SUMMARY OF PROCESS YIELDS, DOR/ER PROCESS

DOR

Oxide Feed

Bulk Wt (g)	4979 (4732 new + 247 casting recycle)
PuO ₂ Wt (g)	4800 (4562 new + 238 casting recycle)
Pu Wt (g)	4231 (4021 new + 210 casting recycle)

Product Plus Residues

Product, Pu (g)	4210 (99.5% yield)
Residue, Pu (g)	21

ANODE CASTING

Feed, g Pu	4210
Product Ingot, g Pu	4000 (95% yield)
Residue, g Pu	210 (recycled to DOR oxide feed)

ELECTROREFINING

Feed Ingot, g Pu	4000
Product ring, g Pu	3300 (82.5% yield)
Residues, g Pu	700

The flowsheet of Fig. 8 has been used to process approximately 250 kg of impure oxide to high-purity metal. Typical purification results are given in Table VII where the purities of an impure oxide feed, impure metal, and high purity product metal are compared. The table demonstrates the excellent purification that can be achieved in the combined DOR/ER process.

TABLE VII

COMPARISON OF PURITIES OF OXIDE FEED, DOR METAL, AND
ER METAL PRODUCT, (Run PMR 162)

Element	g Element/10 ⁶ g Sample		
	Oxide-Feed	Anode Casting	ER Product
B	>150	>150	<1
Na	>233	10	6
Mg	>375	300	1
Al	500	500	<5
Si	283	1400	<5
K	>100	50	15
Ca	>750	100	<3
Ti	32	50	<5
Cr	317	360	<5
Mn	20	10	<1
Fe	>1500	>1500	<5
N	880	940	<5
Cu	24	7	<1
Y	>180	25	<25
Zr	>450	500	<100
Nb	85	60	<10
Mo	121	200	<3
Ta	>500	>500	<100
W	>500	>500	100
Pb	38	<5	<5
Th	421	270	30
U	656	20	7
C	78	790	25
Am	655	795	219
Pu	82.23 (93.29% pure)	98.47	99.96

VI. FUTURE WORK

Work is in progress to improve the efficiencies of both the DOR and electrorefining processes.

The present DOR process would be improved by

(a) recycling the CaCl_2 -CaO salt residues (presently these residues are sent to retrievable storage),

(b) increasing the scale of the reduction,

(c) decreasing the time required for a reduction.

Detailed recommendations for improving the electrorefining process are discussed in Ref. 1. These recommendations include

(a) increasing the scale to 6 kg of plutonium,

(b) decreasing the process time,

(c) improving the process efficiency by increasing the collection efficiency and anode depletion, and

(d) developing pyrochemical procedures⁸ for the recycle of process residues.

REFERENCES

1. L. J. Mullins and A. N. Morgan, "A Review of Operating Experience at the Los Alamos Plutonium Electrorefining Facility, 1963-1967" Los Alamos National Laboratory report LA 8943 (1981).
2. L. J. Mullins and C. L. Foxx, "Direct Reduction of $^{238}\text{PuO}_2$ and $^{239}\text{PuO}_2$ to Metal", Los Alamos National Laboratory report LA 9073 (in press).
3. L. J. Mullins and A. N. Morgan, "Reduction of PuO_2 to Metal", Los Alamos National Laboratory internal documents, CMB-11 Procedures, CMB-11-77-37 Rev 0 (1977) and 420-MPP-R01 (1978).
4. Science, 211, January 9, 1981.
5. D. A. Wenz, I. Johnson, and R. D. Wolson, " CaCl_2 -Rich Region of the CaCl_2 - CaF_2 -CaO System," J. Chem. Eng. Data, 14, [2], 250-252 (1969).
6. L. J. Mullins and J. A. Leary, "Fused-Salt Electrorefining of Molten Plutonium and Its Alloys by the LAMEX Process," I&EC Process Design and Development 4, 394-400 (1965).

7. E. L. Christensen and W. J. Maraman, "Plutonium Processing at the Los Alamos Scientific Laboratory," Los Alamos Scientific Laboratory report LA-3542. (1969).
8. J. B. Knighton, R. G. Auge, and J. C. Brown, "Purification of Plutonium by Oxidation-Reduction Process," Rockwell International report RFP-D 529 (1972).

Printed in the United States of America
 Available from
 National Technical Information Service
 US Department of Commerce
 5285 Port Royal Road
 Springfield, VA 22161
 Microfiche \$3.50 (A01)

Page Range	Domestic Price	NTIS Price Code	Page Range	Domestic Price	NTIS Price Code	Page Range	Domestic Price	NTIS Price Code	Page Range	Domestic Price	NTIS Price Code
001-025	\$ 5.00	A02	151-175	\$11.00	A08	301-325	\$17.00	A14	451-475	\$23.00	A20
026-050	6.00	A03	176-200	12.00	A09	326-350	18.00	A15	476-500	24.00	A21
051-075	7.00	A04	201-225	13.00	A10	351-375	19.00	A16	501-525	25.00	A22
076-100	8.00	A05	226-250	14.00	A11	376-400	20.00	A17	526-550	26.00	A23
101-125	9.00	A06	251-275	15.00	A12	401-425	21.00	A18	551-575	27.00	A24
126-150	10.00	A07	276-300	16.00	A13	426-450	22.00	A19	576-600	28.00	A25
									601-up	†	A99

†Add \$1.00 for each additional 25-page increment or portion thereof from 601 pages up.

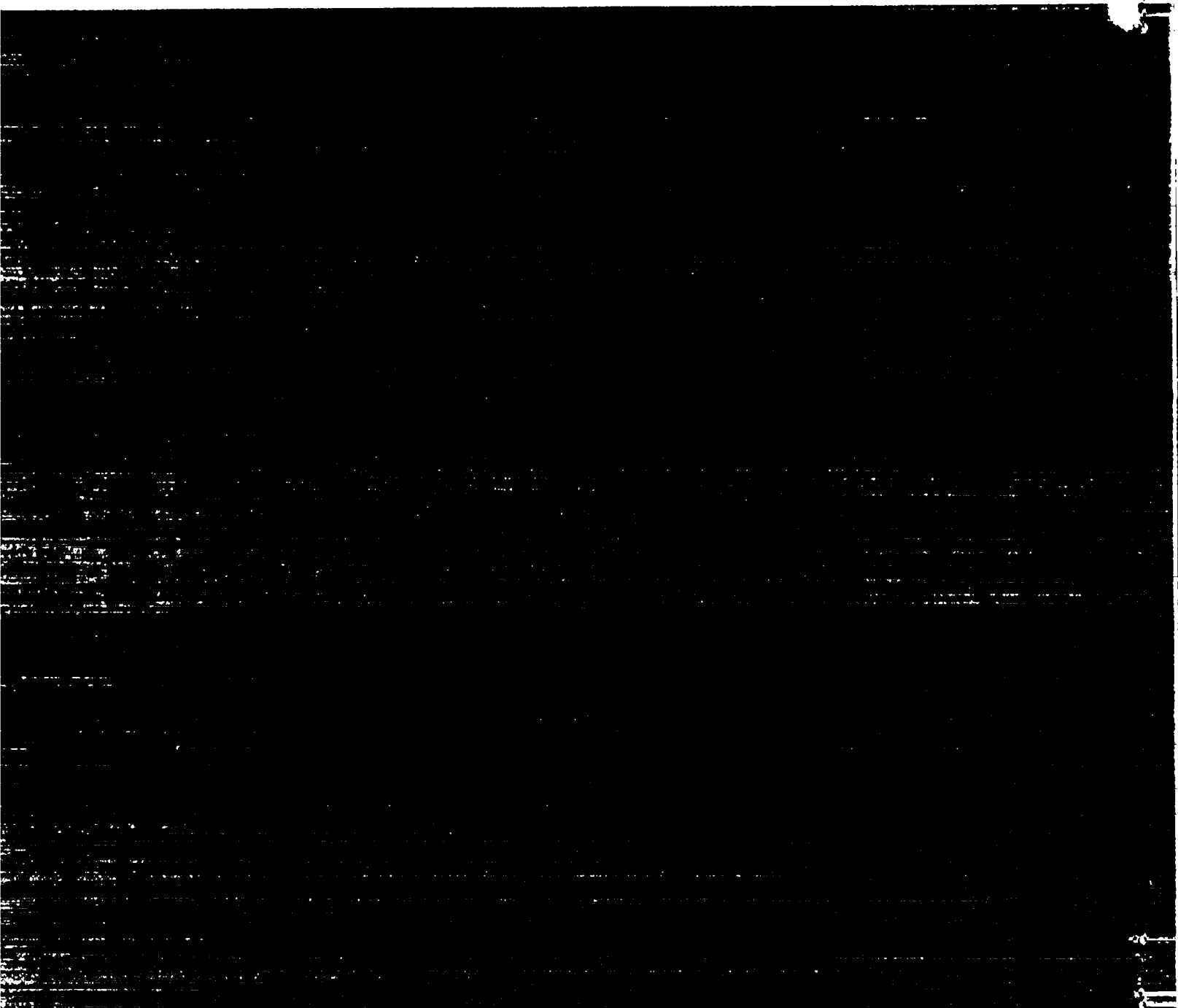

Los Alamos